

Fisher & Paykel



1

Behind every product is a story and that story starts with you. Your kitchen is an expression of who you are and how you enjoy food with others. Our passion is creating better experiences that put the joy of food at the centre of your life. Eat, share, live life — we'll take care of the details.



We have been designing products since 1934 and have grown into a global company operating in 50 countries and manufacturing in the USA, Mexico, Italy, Thailand and New Zealand. Our design heritage is founded on a pioneering spirit and a culture of curiosity that has challenged conventional appliance design to consistently deliver products tailored to human needs. For us, legacy is about looking to the future while ensuring what we develop today is aligned to the fundamental principles of sustainable design. We are committed to ongoing research and development. Our culture is one of open innovation, which allows people to work collaboratively to find insights and ideas that connect with our customers and respect our planet.



Your kitchen is more than just a room; it is the heart and soul of your home. It's a space where you can share delight, fulfill a passion and taste the best life has to offer. Creating a feast for family and friends is one of life's simple pleasures. From our perspective, food needs to be more than just fuel, it needs to be delicious as well. Each of our products has been designed to bring out the chef in you, by making cooking easier more enjoyable. This is what drives us to do what we do — creating experiences that enhance the time we spend together.



We understand that our lives are becoming more complex. We believe in technology that is both leading edge and at the same time human. This approach has led to the development of refrigerators that think for themselves to keep food fresher, and ovens so smart they help clean themselves. Whether it's refrigerators that can change from cooler to freezer at the touch of a button or clothes washers that select the correct wash action for your load — above all we believe in insight-led design that is tailored to people's changing needs around the world.



Food is theatre. From mid week convenience to gourmet weekends, each meal is a performance and the kitchen is your stage. Celebrating great food and cooking from around the world is the show. From the soft crust of a freshly baked baguette to the comforting fragrance of a slow-cooked winter casserole — variety is the spice of life. Just as we seek quality and variety in our food, we desire the same of our kitchens. We are looking for unique appliances that combine innovation with reliability and performance. Savour the taste of your next meal in tomorrow's kitchen.





**Fisher & Paykel
Our Kitchen Blog**

Fisher & Paykel is excited to bring you Our Kitchen, a food blog produced by a group of friends at Fisher & Paykel who share a passion for all things food and cooking. Through delicious recipes and beautiful photography the blog imparts knowledge and advice, inspiring readers in their culinary endeavours. With varying experiences and backgrounds in cooking, every member of the Our Kitchen team brings to the table their own unique perspective on food. As a result we present a collection of recipes which appeal to inspiring foodies of all skills and interests.

Visit www.ourkitchen.fisherpaykel.com for more recipes and cooking ideas.

Frangipane Tart

1 Ingredients

For the pastry:
100g icing sugar
220g flour
40g cocoa
125g butter
2 egg yolks
2 tbsp milk or water

For the frangipane:
70g almonds
70g Brazil nuts
1 tbsp flour
125g butter
125g caster sugar
1 egg
1 tsp vanilla

Seasonal fruit (Strawberries used)

2 Method

Preheat your oven to 180°C, on fan bake.

To make the pastry, blend the very cold butter with the icing sugar, flour and cocoa in a food processor.

Beat the yolks with the milk/cold water and lightly pulse into the flour and butter mixture. Remove from the processor and knead a little on a floured surface to combine (do not over-mix).

Wrap in cling film and chill.

To make the frangipane, grind the almonds and brazil nuts to a breadcrumb consistency (not a fine powder).

Cream the butter and sugar, add the egg then fold in nuts and vanilla. Chill the mixture.

Roll the pastry (to approximately 2-3mm thick) and line a tart shell. Place in the freezer for 10 minutes.

Blind bake the tart shell in your oven for 10 minutes.

Reduce the oven temperature to 160°C.

Add the frangipane to the partially cooked tart shell.

Press in the fruit, which you can do in a pattern or haphazardly.

Bake for approximately 30 minutes or until the frangipane sets.







188

TEMPERATURE



COOK

Whether your preference in Hobs is gas, induction or ceramic, all our Hobs offer precise, consistent, state-of-the-art control. Our built-in ovens and freestanding cookers are designed with the full range of cooking requirements and temperatures, giving you greater flexibility. The most demanding and creative cook can enjoy cooking like a chef and will be thrilled with the flexibility and control of their new Fisher & Paykel range.

90cm Large Capacity Built-in Ovens

Large capacity 90cm cookware is designed for superior performance and to meet a demanding, professional standard in terms of size, quality and craftsmanship.

1 Innovative

Illuminated halos which surround the temperature and function dials tell you if the oven is on and whether or not it has reached the selected temperature.

2 Convenient

Simply set to self-clean and the oven will take care of any grease or grime, reducing it to ash that's easily wiped away with a damp cloth.

3 Ergonomic

Smooth and balanced dial movement allows for easy and precise temperature adjustment.

4 Intuitive

Illuminated function icons, which disappear into the background when off, provide clear user control.

5 Responsive

A spacious cavity designed to accommodate more than a regular oven, allows both side by side and double layered cooking.

6 Precise

Professional quality rotisserie roasts meat to healthy and succulent perfection.

7 Efficient

A powerful 4050W grill gives you an even and fast result, locking in all the flavours and nutrients.

8 Safe

Features cool touch doors that are made of 4 panes of glazed glass and its own cooling system to ensure it's safe to touch.





18:30

- Off
- Auto
- Top Bake
- Broil
- Fan Forced
- Preheat
- Warm
- Keep Warm

FUNCTION



200

TEMPERATURE





60cm Built-in Ovens

Sharing similar features as our larger Built-in Ovens, these 60cm wide ovens will provide years of culinary enjoyment.

- 1 Innovative**
Up to nine functions to choose from to give you flexibility and complete control. Choose the oven function that best suits your dish.

 - 2 Convenient**
Simply set to self-clean and the oven will take care of any grease or grime, reducing it to ash that's easily wiped away with a damp cloth (OB60S9DEP models only).

 - 3 Ergonomic**
Easy-glide telescopic oven runners slide in and out effortlessly, while six shelf positions give you a vast range of options for organising the interior of the oven.

 - 4 Intuitive**
Illuminated halos which surround the temperature and function dials tell you if the oven is on and whether or not it has reached the selected temperature. Each function is pre set to the temperature you are likely to use (OB60S9 models only).

 - 5 Responsive**
The 3000W Grill provides rapid and consistent results, quickly searing food to seal in flavours and nutrients.

 - 6 Precise**
An electronic thermostat controls temperature variation when cooking to ensure consistent temperatures throughout the oven (OB60S9 models only).

 - 7 Safe**
Features cool touch doors that are made of up to 4 panes of glass (3 on non-pyrolytic models) and its own cooling system to ensure it is safe to touch.
-





Freestanding Cookers

Our freestanding cookers give you the flexibility to prepare several courses simultaneously. With extra large or double ovens, combined with a 5 or 6 burner gas hob, the clean lines in glass and stainless steel complement the style and elegance of any kitchen.

-
- 1 Innovative**
Professional performance, offering up to eight oven functions from fan grill to traditional bake and fan forced – perfect for any culinary requirements.

 - 2 Convenient**
The door and its inner pane of glass can be removed for easy, hassle-free cleaning and the storage drawer minimises clutter for all oven accessories.

 - 3 Ergonomic**
Streamlined trivets let you slide pots and pans without lifting them.

 - 4 Precise**
Clear, easy-to-use dials give you exceptional control over cooking temperatures.

 - 5 Efficient**
A powerful grill gives you a fast and even result, locking in all the flavours and nutrients.
-





Gas Hobs

For chefs who prefer the conventional method of cooking, Fisher & Paykel have introduced a range of smart features that make cooking with gas easier, quicker and more convenient than ever before.

-
- 1 Innovative**
Our unique Innovalve™ technology allows you to adjust the flame with unprecedented 180 degree gas valve rotation. Most hobs only offer 70 degree rotation (CG905DWACX1 only).
 - 2 Convenient**
Fisher & Paykel Hobs feature a wide range of burner sizes and power for everything from a slow simmer to a intense heat for steaks and stir-fries.
 - 3 Responsive**
Indicator lights show which burners are in use and alerts you if the gas shuts down (CG905DWACX1 only).
 - 4 Efficient**
Durable heavy-duty cast iron trivets, hard wearing for a long life.
 - 5 Safe**
If the flame is accidentally extinguished, the gas automatically turns off.
 - 6 Reliable**
All Fisher & Paykel gas hobs feature electronic ignition. It is quick, reliable and safe.
-

Induction Hobs

Traditionally we cook by generating heat from one source, such as a flame, and conducting it to another. The Fisher & Paykel Induction Hob works on a different principle. The Hob itself produces electromagnetic vibrations which induce the pot or pan to generate its own heat. The results are shorter heat up times, greater precision and a safer cooking surface.

- 1 Innovative**
Induction cooking means when you change the heat setting it adjusts almost instantly.
 - 2 Convenient**
The intelligent timer lets you activate any combination of cooking zones. Or use the minute minder to manage foods that require precision in cooking.
 - 3 Ergonomic**
Soft touch controls are simple to use and provide great precision. The Hobs are perfectly flat so the surface can be used as an extension of your preparation area.
 - 4 Responsive**
The special PowerBoost function delivers instant, intense heat when you need it. The Hob also has a GentleHeat function for slow, continuous simmering.
 - 5 Safe**
The Hob will alert you if it's turned on without a pot or pan on it, and will switch itself off if you don't respond. The pan detection system switches the Hob off if the pan being used isn't suitable for induction cooking. It also features a parental lock as a safety precaution for children.
 - 6 Eco friendly**
We use ceramic glass in the production of our induction hobs. Our glass is eco-friendly, not using any arsenic or heavy metals in the manufacturing process.
-





Ceramic Hobs

Our ceramic Hobs have a range of built-in features that make cooking easier, while at the same time giving you greater control.

- 1 Innovative**

Ceramic Hobs come with four or five element sizes for cooking flexibility. The auto heat function gives a boost of power to boil the pan quickly, then intelligently reduces to your chosen setting.
- 2 Convenient**

Flat ceramic surfaces for easy cleaning. The intelligent timer lets you activate any combination of cooking elements, or simply use it as a minute minder.
- 3 Ergonomic**

The Touch&Slide is perfectly flat so the surface can be used as an extension of your preparation area.
- 4 Intuitive**

Your choice of classic knob controls or perfectly flat Touch&Slide functionality.
- 5 Responsive**

These Hobs have exceptionally fast heating elements which provide precise temperature control from a rapid boil to an extremely low simmer.
- 6 Safe**

After use, hot surface indicators glow until the surface is safe to touch. In addition, the Touch&Slide Hob will turn off if something spills over the controls.
- 7 Eco friendly**

We use ceramic glass in the production of our ceramic hobs. Our glass is eco-friendly, not using any arsenic or heavy metals in the manufacturing process.





OB90, OB60, OR120, OR90 models

Oven Light: Remains lit while the oven is in use, but can also be used independently from the other cooking functions.



Bake: Heat is provided from the upper and lower elements. A traditional cooking mode, suitable for single shelf cooking of items like cakes, delicate items like sponges, custard tart and crème brûlée.



Fan Bake (excludes OB60HCEX2, OB60HDEX2 models): The oven fan circulates hot air from upper and lower elements and distributes it around the cavity. Food browns more quickly, great for crisping pastry. Suitable for robust items like cookies, scones and muffins.



Classic Bake: Uses the heat from the lower element only. This is a traditional cooking mode which is suitable for recipes that were developed in older ovens. For best results, cook on only one shelf at a time. Perfect for foods that require delicate cooking and have a pastry base, like custard tarts, quiches and cheesecake or anything that does not require direct heat and browning on the top surface.



Pastry Bake / Fan Forced with Lower Heat (OB90S9M, OB60SCTX3 models only): The lower heating element and fan provide outstanding cooking performance.



Roast: A two step programme that has been developed to help you cook delicious roasts effortlessly. This function is a combination of grill and bake, grilling your food for the first 20 minutes it then bakes at the set temperature for the rest of your cooking time. This sears the meat to keep in the juices.



Grill: The grill element delivers heat for fast, healthy grilling. Perfect for tender meat cuts, toasting and crisping.



Fan Grill: The oven fan circulates hot air from the top element for high speed grilling and produces food with a finish that is similar to a rotisserie. Food is crisp and brown on the outside while the inside remains moist and tender.



Fan Forced: A very flexible method of cooking. A concealed element surrounding the fan at the rear of the oven heats air which is then distributed evenly around the cavity. This is the ideal mode for multi-shelf cooking and complete oven meals.



Defrost: The oven fan circulates air around the oven, speeding up the defrosting process by up to 30%.



Warm (excludes OB90S9M, OB60S9D, OB60SCTX3, OB60HCEX2, OB60HDEX2 models): Use this function to keep cooked food hot and to warm plates and serving dishes.



Warm (OB90S9M, OB60S9D models only): Use this function to keep cooked food hot and to warm plates and serving dishes.



Pyrolytic Self Clean (OB90S9M, OB60S9DEPX1 models only): During the self clean cycle, the oven reaches higher temperatures than it does for cooking, breaking down soil and grease deposits which can be wiped away with a damp cloth.



Rotisserie (OB90S9M model only): A delicious way to cook meat and poultry. The slowly rotating food is basted continuously in its own juices, making it tender on the inside and well browned and full of flavour on the outside.



Pastry Assist (OB60SCTX3 model only): The lower element and the oven fan are on. This function is for foods that require a higher temperature at the bottom than the top.



Turbo Grill (OB60SCTX3 model only): Powerful 3000W element delivers intense heat over the whole width of the oven. Fast, efficient grilling.



Defrost/Warm (OB60SCTX3 model only): The lower heating element and oven fan provide the ability to defrost and will keep food warm within 75°C and 100°C.

Sabbath mode (OB90S9M, OB60S9DEX1, OB60S9DEPX1 models only): This setting is designed for religious faiths that observe a 'no work' requirement on the Sabbath. It is used in conjunction with the **Bake**  function.

Built-in Ovens



90cm Pyrolytic Built-in Oven
 OB90S9MEPX1 **Kitchen Studio Exclusive**
 Stainless Steel
 Designer with Designer handle

Dimensions: H478 x W896 x D566 mm

Useable capacity: 79 litres **Shelf positions:** 4

9 Oven functions:

Energy rating*: C

Performance: 4050W Grill

Cleaning: Pyrolytic self clean, High acid resistant graphite enamel interior, Removable shelf runners, Removable oven door, Removable inner door glass

Safety: Cool touch quadruple glazed doors, Door and cavity cooling system, Non-tip shelves, Control panel key lock, Catalytic venting system

Controls: Electronic clock, Automatic cooking/minute timer, 2 x Side lights, Electronic temperature control, Illuminated halo dials, 2 Halogen lights (sides), Sabbath mode, Pre-set cooking temperatures

AMP Draw: 19.1A

Accessories: 1 Oven shelf, 1 Step down oven shelf, 1 Two piece anti-splatter grill system, 1 Brushed aluminium baking tray, 1 Rotisserie system, 1 set of plastic grill pan handles

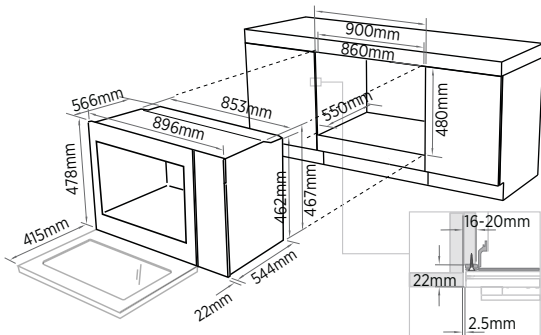

Note: If installing a hob above the oven, ensure adequate clearance is provided for the hob as per the hob manufacturer's instructions.
 Overall depth of product excludes handle and knobs.
 All height measurements include mounted feet.



60cm Tower Built-in Oven
 OB60DDEX3 **Kitchen Studio Exclusive**
 Stainless Steel
 Designer with Designer handle

Dimensions: H1077 x W595 x D567 mm

Useable capacity: 53 + 53 litres **Shelf positions:** 6 per cavity

8/8 Oven functions: Top:
 Bottom:

Energy rating*: A/A

Performance: 3000W Grill

Cleaning: High acid resistant graphite enamel interior, Drop down grill element, Self cleaning catalytic liners (sides and rear), Removable shelf runners, Removable oven doors, Removable inner door glass

Safety: Cool touch triple glazed doors, Door and cavity cooling system, Non-tip shelves

Controls: Electronic clock, Automatic cooking/minute timer (top), Side and rear lights (both)

AMP Draw: 27A

Accessories: 4 sets of Telescopic slide runners, 2 Oven shelves, 2 Step down oven shelves, 1 Two piece anti-splatter grill system, 2 Brushed aluminium baking trays, 2 Fat filters, 1 set of plastic grill pan handles

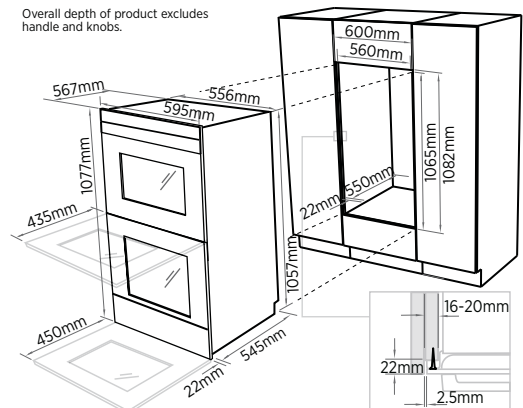

Overall depth of product excludes handle and knobs.

2 YEAR WARRANTY

*Tested according to European Standard EN50304.

2 YEAR WARRANTY

*Tested according to European Standard EN50304.



60cm Double Built-in Oven
OB60B77DEX2 Kitchen Studio Exclusive
 Stainless Steel
 Designer with Designer handle

Dimensions: H888 x W595 x D567 mm

Useable capacity: 53 + 35 litres **Shelf positions:** 6 (bottom), 4 (top)

8/8 Oven functions: Top: 
 Bottom: 

Energy rating*: A/A

Performance: 3000W Grill (bottom), 2700W Grill (top)

Cleaning: High acid resistant graphite enamel interior, Drop down grill element (bottom), Self cleaning catalytic liners sides and rear (bottom), Removable shelf runners, Removable oven doors, Removable inner door glass

Safety: Cool touch triple glazed doors, Door and cavity cooling system, Non-tip shelves

Controls: Electronic clock, Automatic cooking/minute timer (bottom), Rear light (top), Side and rear lights (bottom)

AMP Draw: 25.4A

Accessories: 3 sets of Telescopic slide runners, 2 Oven shelves, 1 Step down oven shelf, 1 Two piece anti-splatter grill system, 1 Brushed aluminium baking tray, 1 Fat filter (bottom), 1 set of plastic grill pan handles

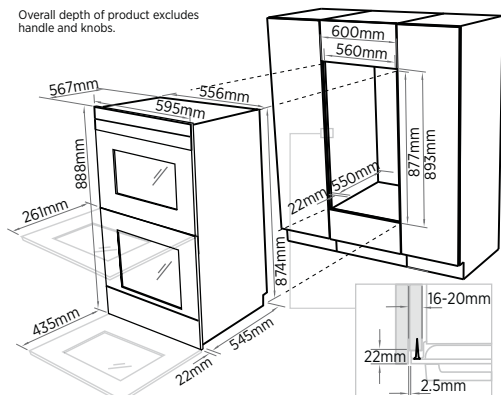

60cm Double Built-in Oven
OB60B77CEX2
 Stainless Steel
 Classic with Curved handle

Dimensions: H888 x W595 x D567 mm

Useable capacity: 53 + 35 litres **Shelf positions:** 6 (bottom), 4 (top)

8/8 Oven functions: Top: 
 Bottom: 

Energy rating*: A/A

Performance: 3000W Grill (bottom), 2700W Grill (top)

Cleaning: High acid resistant graphite enamel interior, Drop down grill element (bottom), Self cleaning catalytic liners sides (bottom), Removable shelf runners, Removable oven doors, Removable inner door glass

Safety: Cool touch triple glazed doors, Door and cavity cooling system, Non-tip shelves

Controls: Electronic clock, Automatic cooking/minute timer (bottom), Rear light (top), Side and rear lights (bottom)

AMP Draw: 25.4A

Accessories: 2 sets of Telescopic slide runners, 2 Oven shelves, 1 Step down oven shelf, 1 Two piece anti-splatter grill system, 1 Brushed aluminium baking tray, 1 Fat filter (bottom), 1 set of wire grill pan handles

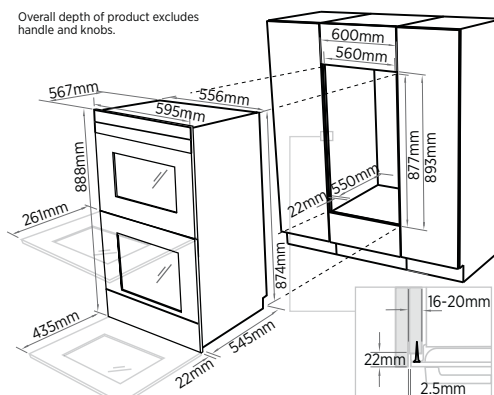



60cm Double Built-in Oven

OB60BCEX3
Stainless Steel
Classic with Curved handle

Dimensions: H888 x W595 X D567 mm

Useable capacity: 53 + 35 litres **Shelf positions** 6 (bottom) 4 (top)

3/8 Oven functions: Top:  Bottom: 

Energy rating*: A/A

Performance: 3000W Grill (bottom), 2700W Grill (top)

Cleaning: High acid resistant graphite enamel interior, Drop down grill element (bottom), Self cleaning catalytic liners sides (bottom), Removable shelf runners, Removable oven doors, Removable inner door glass (bottom)

Safety: Cool touch triple glazed doors, Door and cavity cooling system, Non-tip shelves

Controls: Electronic clock, Automatic cooking/minute timer (bottom), Rear light (top), Side and rear lights (bottom)

AMP Draw: 19.3A

Accessories: 2 sets of Telescopic slide runners, 2 Oven shelves, 1 Step down oven shelf, 1 Two piece anti-splatter grill system, 1 Brushed aluminium baking tray, 1 Fat filter (bottom), 1 set of wire grill pan handles

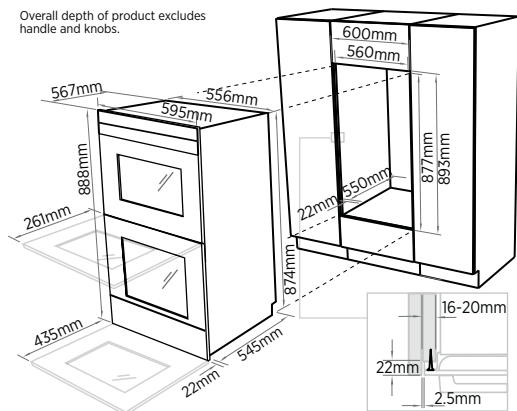



60cm Under Counter Built-in Oven

OB60HDEX2 **Kitchen Studio Exclusive**
Stainless Steel
Designer with Designer handle

Dimensions: H718 x W595 x D564 mm

Useable capacity: 50 + 35 litres **Shelf positions:** 4 (bottom) 4 (top)

3/4 Oven functions: Top:  Bottom: 

Energy rating*: A/A

Performance: 2000W Grill

Cleaning: High acid resistant graphite enamel interior, Self cleaning catalytic liners sides (bottom), Removable shelf runners, Removable oven doors

Safety: Door and cavity cooling system, non-tip shelves

Controls: Electronic clock, Automatic cooking/timer (bottom), Rear light

AMP Draw: 17.65A

Accessories: 3 sets of Telescopic slide runners, 2 Oven shelves, 1 Step down oven shelf, 1 Two piece anti-splatter grill system, 1 Fat filter (bottom), 1 set of plastic grill pan handles

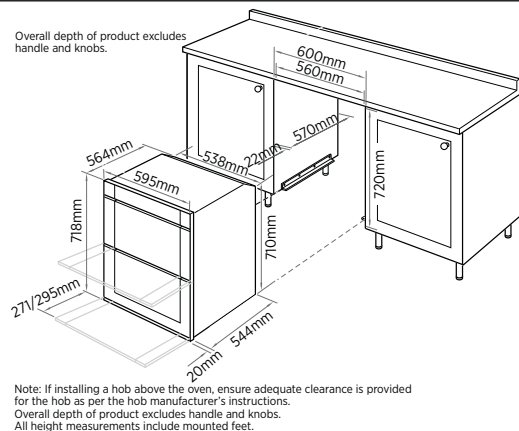

2 YEAR WARRANTY

*Tested according to European Standard EN50304.

2 YEAR WARRANTY

*Tested according to European Standard EN50304.



60cm Under Counter Built-in Oven

OB60HCEX2
Stainless Steel
Classic with Curved handle

Dimensions: H718 x W595 x D564 mm

Useable capacity: 50 + 35 litres **Shelf positions:** 4 (bottom) 4 (top)

3/4 Oven functions: Top: Bottom:

Energy rating*: A/A

Performance: 2000W Grill

Cleaning: High acid resistant graphite enamel interior, Removable shelf runners, Removable oven doors

Safety: Door and cavity cooling system, non-tip shelves

Controls: Electronic clock, Automatic cooking/timer (bottom), Rear light

AMP Draw: 17.65A

Accessories: 2 sets of Telescopic slide runners, 2 Oven shelves, 1 Step down oven shelf, 1 Two piece anti-splatter grill system, 1 Fat filter (bottom), 1 set of wire grill pan handles

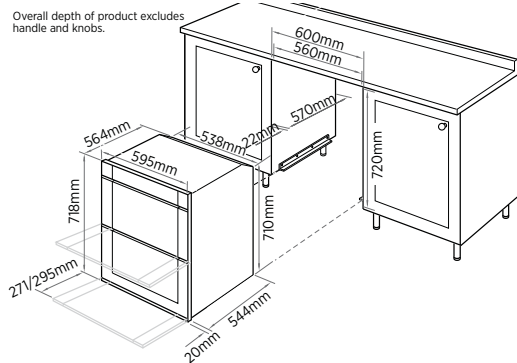

Note: If installing a hob above the oven, ensure adequate clearance is provided for the hob as per the hob manufacturer's instructions. Overall depth of product excludes handle and knobs. All height measurements include mounted feet.

2 YEAR WARRANTY

*Tested according to European Standard EN50304.



60cm Single Pyrolytic Built-in Oven

OB60S9DEPX1 **Kitchen Studio Exclusive**
Stainless Steel
Designer with Designer handle

Dimensions: H597 x W595 x D567 mm

Useable capacity: 52 litres **Shelf positions:** 6

9 Oven functions:

Energy rating*: B

Performance: 3000W Grill

Cleaning: Pyrolytic self clean, High acid resistant graphite enamel interior, Removable shelf runners, Removable oven door, Removable inner door glass

Safety: Cool touch quadruple glazed glass door, Door and cavity cooling system, Non-tip shelves, Catalytic venting system, Control panel key lock, Telescopic slide runners

Controls: Electronic clock, Automatic cooking/minute timer, Illuminated halo dials, Rear light, Electronic temperature control, Sabbath mode, Pre-set cooking temperatures

AMP Draw: 16A

Accessories: 2 sets of Telescopic slide runners, 1 Oven shelf, 1 Step down oven shelf, 1 Two piece anti-splatter grill system, 1 Brushed aluminium baking tray, 1 set of plastic grill pan handles

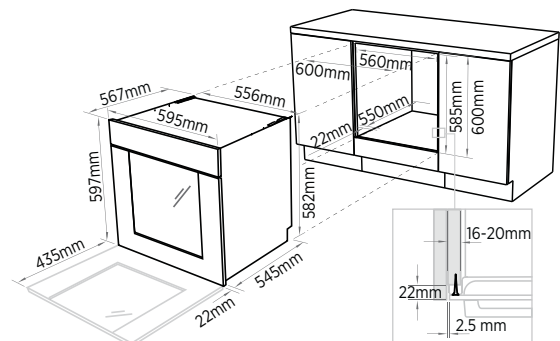

Note: If installing a hob above the oven, ensure adequate clearance is provided for the hob as per the hob manufacturer's instructions. Overall depth of product excludes handle and knobs. All height measurements include mounted feet.

2 YEAR WARRANTY

*Tested according to European Standard EN50304.



60cm Single Built-in Oven
 OB60S9DEX1 Kitchen Studio Exclusive
 Stainless Steel
 Designer with Designer handle

Dimensions: H597 x W595 x D567 mm

Useable capacity: 53 litres **Shelf positions:** 6

9 Oven functions:

Energy rating*: A

Performance: 3000W Grill

Cleaning: High acid resistant graphite enamel interior, Drop down grill element, Self cleaning catalytic liners (sides and rear), Removable shelf runners, Removable oven door, Removable inner door glass

Safety: Cool touch triple glazed glass door, Door and cavity cooling system, Non-tip shelves, Control panel key lock, Telescopic slide runners

Controls: Electronic clock, Automatic cooking/minute timer, Illuminated halo dials, Side and rear lights, Electronic temperature control, Sabbath mode, Pre-set cooking temperatures

AMP Draw: 16A

Accessories: 2 sets of Telescopic slide runners, 1 Oven shelf, 1 Step down oven shelf, 1 Two piece anti-splatter grill system, 1 Brushed aluminium baking tray, 1 Fat filter, 1 set of plastic grill pan handles

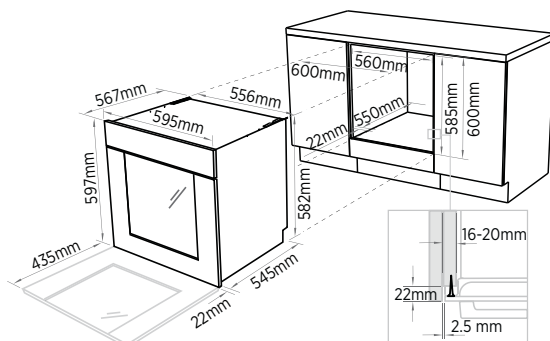

Note: If installing a hob above the oven, ensure adequate clearance is provided for the hob as per the hob manufacturer's instructions.
 Overall depth of product excludes handle and knobs.
 All height measurements include mounted feet.

2 YEAR WARRANTY

*Tested according to European Standard EN50304.



60cm Single Built-in Oven
 OB60SCEX3
 Stainless Steel
 Classic with Curved handle

Dimensions: H597 x W595 x D567 mm

Useable capacity: 53 litres **Shelf positions:** 6

8 Oven functions:

Energy rating*: A

Performance: 3000W Grill

Cleaning: High acid resistant graphite enamel interior, Drop down grill element, Self cleaning catalytic liners (sides), Removable shelf runners, Removable oven door, Removable inner door glass

Safety: Cool touch triple glazed glass door, Door and cavity cooling system, Non-tip shelves, Telescopic slide runners

Controls: Electronic clock, Automatic cooking/minute timer, Side and rear lights

AMP Draw: 13.4A

Accessories: 1 set of Telescopic slide runners, 1 Oven shelf, 1 Step down oven shelf, 1 Two piece anti-splatter grill system, 1 Fat filter, 1 set of wire pan handles

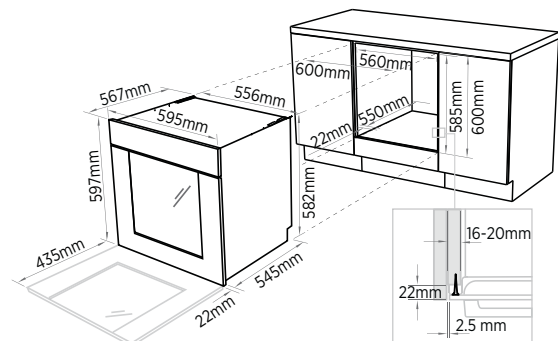

Note: If installing a hob above the oven, ensure adequate clearance is provided for the hob as per the hob manufacturer's instructions.
 Overall depth of product excludes handle and knobs.
 All height measurements include mounted feet.

2 YEAR WARRANTY

*Tested according to European Standard EN50304.



60cm Compact Built-In Oven
OB60NDEX1 Kitchen Studio Exclusive
 Stainless Steel
 Designer with Designer handle

Dimensions: H450 x W595 x D556 mm

Useable capacity: 35 litres **Shelf positions:** 4

8 Oven functions:

Energy rating*: A

Performance: 2700W Grill

Cleaning: High acid resistant graphite enamel interior, Removable shelf runners, Removable oven door, Removable inner door glass

Safety: Cool touch triple glazed glass door, Door and cavity cooling system, Non-tip shelves

Controls: Electronic clock, Automatic cooking/minute timer, Rear light

AMP Draw: 12.8A

Accessories: 1 Step down oven shelf, 1 Two piece anti-splatter grill system, 1 Brushed aluminium baking tray, 1 Fat filter, Optional trim kit to increase height to 480mm (part number 89168)

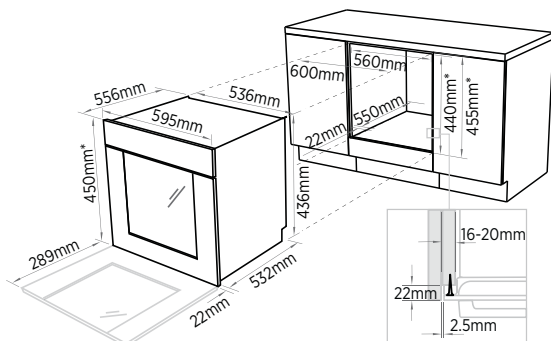

Note: If installing a hob above the oven, ensure adequate clearance is provided for the hob as per the hob manufacturer's instructions.
 Overall depth of product excludes handle and knobs.
 *If fitting the lower trim extension kit, the overall height of product increases by 25mm.

2 YEAR WARRANTY

*Tested according to European Standard EN50304.



60cm Compact Built-In Oven
OB60NCEX1 Kitchen Studio Exclusive
 Stainless Steel
 Classic with Curved handle

Dimensions: H450 x W595 x D556 mm

Useable capacity: 35 litres **Shelf positions:** 4

8 Oven functions:

Energy rating*: A

Performance: 2700W Grill

Cleaning: High acid resistant graphite enamel interior, Removable shelf runners, Removable oven door, Removable inner door glass

Safety: Cool touch triple glazed glass door, Door and cavity cooling system, Non-tip shelves

Controls: Electronic clock, Automatic cooking/minute timer, Rear light

AMP Draw: 12.8A

Accessories: 1 Step down oven shelf, 1 Two piece anti-splatter grill system, 1 Brushed aluminium baking tray, 1 Fat filter, Optional trim kit to increase height to 480mm (part number 89168)

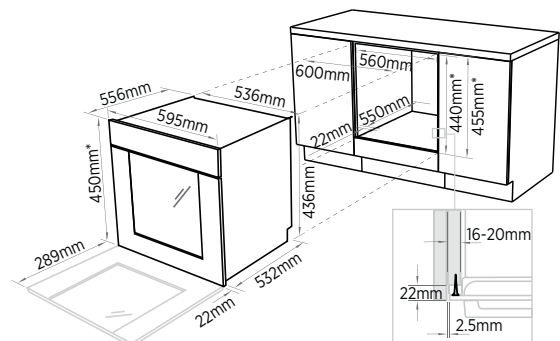

Note: If installing a hob above the oven, ensure adequate clearance is provided for the hob as per the hob manufacturer's instructions.
 Overall depth of product excludes handle and knobs.
 *If fitting the lower trim extension kit, the overall height of product increases by 25mm.

2 YEAR WARRANTY

*Tested according to European Standard EN50304.

Range Cookers



120cm Range Cooker
 OR120DDWG1
 Stainless Steel
 Designer with Designer handle

Dimensions: H min 1035 - max 1047 x W1200 x D600 mm
 With Splashback: H min 1035 - max 1047 x W1200 x D600 mm

Useable capacity: 53 + 53 litres **Shelf positions:** 4 + 4

8/8 Oven functions: Main: 
 Second: 

Energy rating*: A/A

Performance: 2000W Grill, 3.5kW wok burner, 4.5kW dual burner (burner ratings shown for Natural Gas connections only), Humidity controlled warming drawer,

Gas Hob: 6 Gas burners including wok burner, Electronic ignition, Natural Gas fitted/LPG compatible, Cast iron trivets

Cleaning: Hard wearing grey enamel interior, Drop down grill element, Removable oven door, Removable inner door glass

Safety: Cool touch triple glazed door, Door and cavity cooling system, Non-tip shelves, Anti tilt bracket, Flame failure device

Controls: Electronic clock, Automatic cooking/minute timer

AMP Draw: 23A

Accessories: 2 Oven shelves, 2 Step down oven shelves, 2 Brushed aluminium baking trays, 2 two piece anti-splatter grill systems, 2 Fat filters, 1 Set of plastic grill pan handles, 1 Wok stand, 1 Cast iron skillet, 1 LPG Conversion Kit, 1 Storage compartment, 1 Splashback

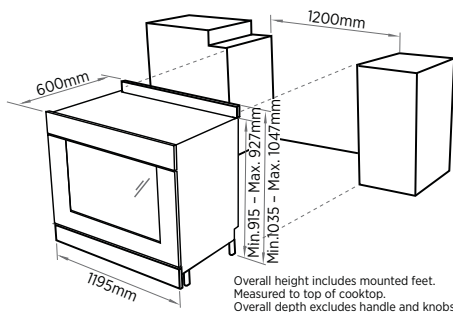

90cm Range Cooker
 OR90LDBGX1
 Stainless Steel
 Designer with Designer handle

Dimensions: H min 900 - max 925 x W897 x D600 mm
 With Splashback: H min 960 - max 985 x W897 x D600 mm

Useable capacity: 60 + 35 litres **Shelf positions:** 4 + 4

8/3 Oven functions: Main: 
 Second: 

Energy rating*: C/B

Performance: 2000W Grill, 3.5kW wok burner (burner ratings shown for Natural Gas connections only)

Gas Hob: 5 Gas burners including wok burner, Electronic ignition, Natural Gas fitted/LPG compatible, Cast iron trivets

Cleaning: Hard wearing grey enamel interior, Drop down grill element

Safety: Double glazed door, Door and cavity cooling system, Non-tip shelves, Anti tilt bracket, Flame failure device

Controls: Electronic clock, Automatic cooking/minute timer (main)

AMP Draw: 15.2A

Accessories: 2 Oven shelves, 2 Two piece anti-splatter grill systems, 1 Set of plastic grill pan handles, 1 Plate warming rack, 1 Wok stand, 1 Storage compartment, 1 Splashback, 1 Fat filter, 1 LPG conversion kit

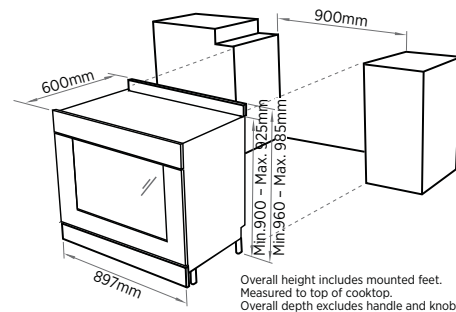

2 YEAR WARRANTY

*Tested according to European Standard EN50304.

2 YEAR WARRANTY

*Tested according to European Standard EN50304.



90cm 5 Burner Gas Hob
 CG905DWACX1 **Kitchen Studio Exclusive**
 Stainless Steel
 Designer

Dimensions: W914 x D546 x H76 mm

Burners: 5 including 1 wok burner

Burner ratings: 0.2 kW Auxiliary burner
 1.9 kW Semi rapid burner
 5.5 kW Wok burner
 2.0 kW Rapid burners

Burner ratings shown for Natural Gas connections only

Performance: Innovolve™ technology, Electronic ignition, LPG and Natural gas compatible, Cast iron trivets

Cleaning: Easy clean hob design, Quick component removal

Safety: Auto re-ignition system, 4 litres Spill containment, Flame failure device

Controls: Cast alloy satin chrome control dials, Burner indicator lights/
 Fault indication, Permanent laser etched graphics

AMP Draw: 10A

Supply voltage: 230 - 240

Accessories: N/A

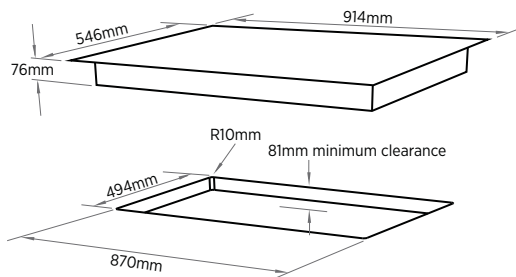

Note: The appliance should be installed in a room or space with an air supply in accordance with BS5440:2 2000. Please check installation instructions for required clearances around cooktop.

2 YEAR WARRANTY



90cm 5 Burner Gas Hob
 CG905DWFCX1
 Stainless Steel
 Designer

Dimensions: W914 x D533 x H50 mm

Burners: 5 including 2 wok burners

Burner ratings: 0.3 kW Auxiliary burner
 1.9 kW Semi rapid burners
 3.6 kW Wok burners

Burner ratings shown for Natural Gas connections only

Performance: Electronic ignition, Quick connect gas valve, LPG and Natural gas compatible, Cast iron trivets

Cleaning: Easy clean hob design, Quick component removal

Safety: 2.5 litres Spill containment, Flame failure device

Controls: Cast alloy satin chrome control dials, Permanent laser etched graphics

AMP Draw: 10A

Supply voltage: 230 - 240

Accessories: Wok stand

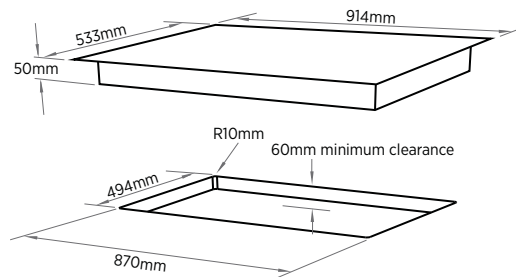

Note: The appliance should be installed in a room or space with an air supply in accordance with BS5440:2 2000. Please check installation instructions for required clearances around cooktop.

2 YEAR WARRANTY



75cm 5 Burner Gas Hob

CG755DWFCTB1

Glass with Stainless Trim
Designer

Dimensions: W750 x D510 x H54 mm

Burners: 5 including 1 wok burner

Burner ratings: 0.3 kW Auxiliary burner
1.75 kW Semi rapid burner
3.5 kW Wok burner
3.0 kW Rapid burners

Burner ratings shown for Natural Gas connections only

Performance: Electronic ignition, Quick connect gas valve, LPG and Natural gas compatible, Cast iron trivets

Cleaning: Easy clean glass finish, Easy clean hob design, Quick component removal

Safety: Flame failure device

Controls: Cast alloy satin chrome control dials, Permanent laser etched graphics

AMP Draw: 10A

Supply voltage: 230 - 240

Accessories: Wok stand

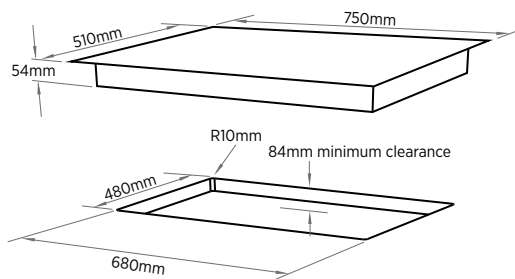

Note: The appliance should be installed in a room or space with an air supply in accordance with BS5440:2 2000. Please check installation instructions for required clearances around cooktop.

**2 YEAR
WARRANTY**



70cm 5 Burner Gas Hob

CG705CWFCX1

Stainless Steel
Classic

Dimensions: W680 x D500 x H35 mm. Fits into a 60cm cutout.

Burners: 5 including 1 wok burner

Burner ratings: 0.3 kW Auxiliary burner
1.75 kW Semi rapid burner
3.5 kW Wok burner
3.0 kW Rapid burners

Burner ratings shown for Natural Gas connections only

Performance: Electronic ignition, Quick connect gas valve, LPG and Natural gas compatible, Cast iron trivets

Cleaning: Easy clean hob design, Quick component removal

Safety: 2 litres Spill containment, Flame failure device

Controls: Cast alloy satin chrome control dials, Permanent laser etched graphics

AMP Draw: 10A

Supply voltage: 230 - 240

Accessories: Wok stand, Small pan support

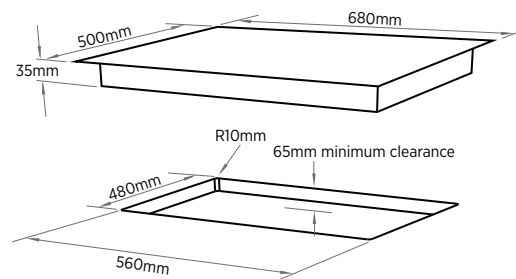

Note: The appliance should be installed in a room or space with an air supply in accordance with BS5440:2 2000. Please check installation instructions for required clearances around cooktop.

**2 YEAR
WARRANTY**



60cm 4 Burner Gas Hob

CG604DFCTB1
Glass with Stainless Trim
Designer

Dimensions: W600 x D510 x H54 mm

Burners: 4

Burner ratings: 0.3 kW Auxiliary burner
1.75 kW Semi rapid burner
3.0 kW Rapid burners

Burner ratings shown for Natural Gas connections only

Performance: Electronic ignition, Quick connect gas valve, LPG and Natural gas compatible, Cast iron trivets

Cleaning: Easy clean glass finish, Quick component removal

Safety: Flame failure device

Controls: Cast alloy satin chrome control dials, Permanent laser etched graphics

AMP Draw: 10A

Supply voltage: 230 - 240

Accessories: N/A

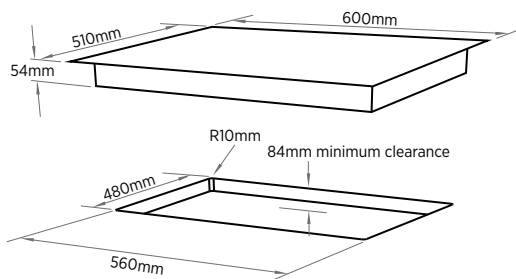

Note: The appliance should be installed in a room or space with an air supply in accordance with BS5440:2 2000. Please check installation instructions for required clearances around cooktop.

2 YEAR WARRANTY



60cm 4 Burner Gas Hob

CG604DWFCX1
Stainless Steel
Designer

Dimensions: W578 x D511 x H50 mm

Burners: 4 including 1 wok burner

Burner ratings: 0.3kW auxiliary burner
1.9kW semi rapid burner
3.6kW wok burner

Burner ratings shown for Natural Gas connections only

Performance: Electronic ignition, Quick connect gas valve, LPG and Natural gas compatible, Cast iron trivets

Cleaning: Easy clean hob design, Quick component removal

Safety: 1.5 litres Spill containment, Flame failure device

Controls: Cast alloy satin chrome control dials, Permanent laser etched graphics

AMP Draw: 10A

Supply voltage: 230 - 240

Accessories: Wok stand

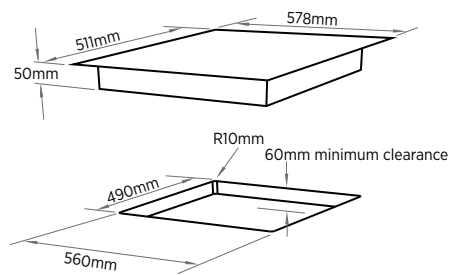

Note: The appliance should be installed in a room or space with an air supply in accordance with BS5440:2 2000. Please check installation instructions for required clearances around cooktop.

2 YEAR WARRANTY



90cm 5 Zone Induction Hob
 CI905DTB1 **Kitchen Studio Exclusive**
 Ceramic Glass
 Designer

Dimensions: W900 x D530 x H55 mm

Cooking zones: 5

Zone ratings: 2300W (3200W*) Left front
 1850W (2500W*) Right front
 1400W (1800W*) Left rear
 1850W (2500W*) Right rear
 2400W (3700W*) Centre
 up to 3.7kW PowerBoost

* Maximum power output when set for PowerBoost

Performance: Induction cooking technology, 9 Heat settings, Auto heat reduce, GentleHeat, PowerBoost

Cleaning: Flat easy clean glass surface

Safety: Key lock, Safety time out, Pan detection system, Surface hot indicators, Spillage auto off

Controls: Soft touch electronic controls, Minute timer, Auto cut-off timer for each zone

AMP Draw: 42A

Supply voltage: 230 – 240

Accessories: N/A

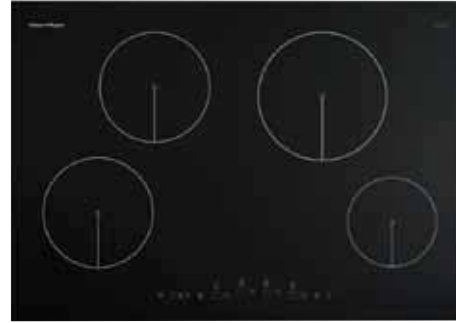
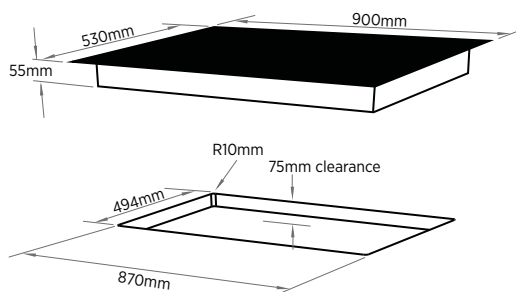

75cm 4 Zone Induction Hob
 CI754DTB1
 Ceramic Glass
 Designer

Dimensions: W750 x D530 x H55 mm

Cooking zones: 4

Zone ratings: 1850W (2500W*) Left front
 1400W (1800W*) Right front
 1850W (2500W*) Left rear
 2300W (3700W*) Right rear
 up to 3.7kW PowerBoost

* Maximum power output when set for PowerBoost

Performance: Induction cooking technology, 9 Heat settings, Auto heat reduce, GentleHeat, PowerBoost

Cleaning: Flat easy clean glass surface

Safety: Key lock, Safety time out, Pan detection system, Surface hot indicators, Spillage auto off

Controls: Soft touch electronic controls, Minute timer, Auto cut-off timer for each zone

AMP Draw: 32A

Supply voltage: 230 – 240

Accessories: N/A

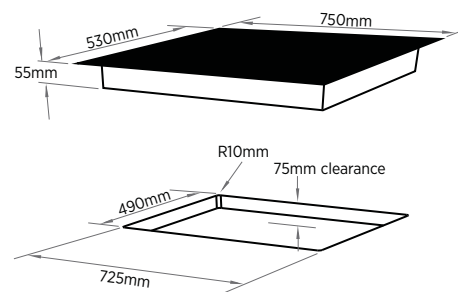

**2 YEAR
 WARRANTY**

**2 YEAR
 WARRANTY**



60cm 4 Zone Induction Hob

CI604DTB1
Ceramic Glass
Designer

Dimensions: W600 x D530 x H55 mm

Cooking zones: 4

Zone ratings: 2300W (3700W*) Left front
1400W (1800W*) Right front
1400W (1800W*) Left rear
1850W (2500W*) Right rear
up to 3.7kW PowerBoost

* Maximum power output when set for PowerBoost

Performance: Induction cooking technology, 9 Heat settings, Auto heat reduce, GentleHeat, PowerBoost

Cleaning: Flat easy clean glass surface

Safety: Key lock, Safety time out, Pan detection system, Surface hot indicators, Spillage auto off

Controls: Soft touch electronic controls, Minute timer, Auto cut-off timer for each zone

AMP Draw: 30A

Supply voltage: 230 – 240

Accessories: N/A

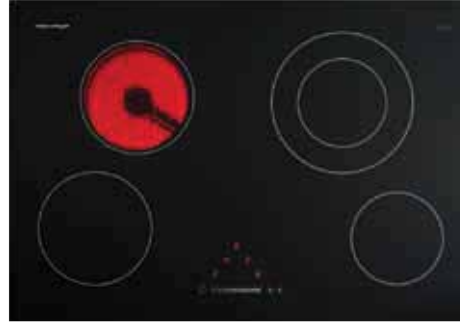
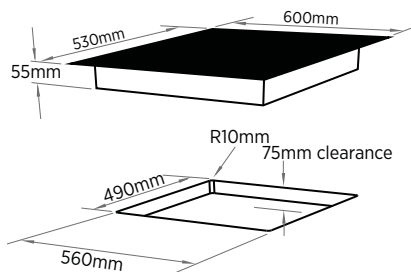

75cm 4 Element Ceramic Hob

CE754DTB1
Ceramic Glass
Designer

Dimensions: W750 x D530 x H58 mm

Elements: 4 including 1 dual element

Element ratings: 1800W Left front
1200W Right front
1200W Left rear
2500W/1100W Right rear
15W GentleHeat

Performance: Hi-light high speed ribbon elements, Dual element, Auto heat reduce

Cleaning: Flat easy clean glass surface

Safety: Key lock, Safety time out, Individual hot surface indicators, Temperature limiters, Spillage auto off

Controls: Touch&Slide electronic controls, Minute timer, Auto cut-off timer for each element

AMP Draw: 32A

Supply voltage: 230 – 240

Accessories: N/A

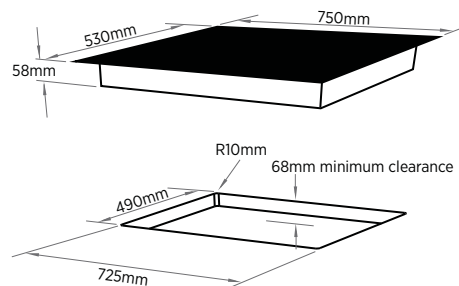

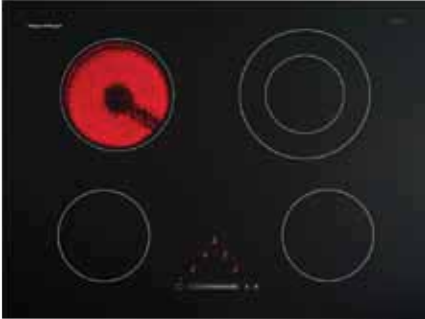

70cm 4 Element Ceramic Hob

CE704DTB1
Ceramic Glass
Designer

Dimensions: W700 x D530 x H58 mm. Fits into a 60cm cutout.

Burners: 4 including 1 dual element

Element ratings: 1200W Left front
1200W Right front
1800W Left rear
2200/750W Right rear
15W GentleHeat

Performance: Hi-light high speed ribbon elements, Dual element, Auto heat reduce

Cleaning: Flat easy clean glass surface

Safety: Key lock, Safety time out, Individual hot surface indicators, Temperature limiters, Spillage auto off

Controls: Touch&Slide electronic controls, Minute timer, Auto cut-off timer for each element

AMP Draw: 28A

Supply voltage: 230 - 240

Accessories: N/A

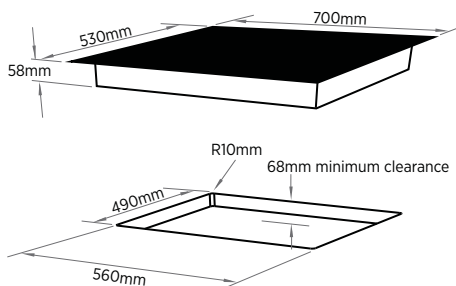

**2 YEAR
WARRANTY**



60cm 4 Element Ceramic Hob

CE604DTB1
Ceramic Glass
Designer

Dimensions: W600 x D530 x H58 mm

Elements: 4 including 1 dual element

Element ratings: 1200W Left front
1200W Right front
1800W Left rear
2200/750W Right rear
15W GentleHeat

Performance: Hi-light high speed ribbon elements, Dual element, Auto heat reduce

Cleaning: Flat easy clean glass surface

Safety: Key lock, Safety time out, Individual hot surface indicators, Temperature limiters, Spillage auto off

Controls: Touch&Slide electronic controls, Minute timer, Auto cut-off timer for each element

AMP Draw: 28A

Supply voltage: 230 - 240

Accessories: N/A

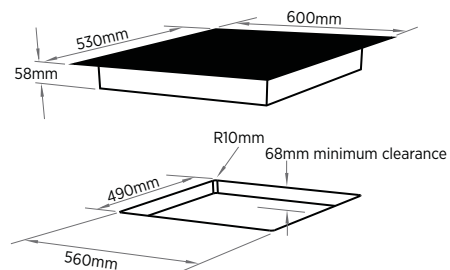

**2 YEAR
WARRANTY**



90cm 5 Element Ceramic Hob

CE905CBX1
Ceramic Glass with Stainless Trim
Classic

Dimensions: W900 x D530 x H59 mm

Elements: 5 including 2 dual elements

Element ratings: 1700W/700W Left front
1200W Right front
1800W Left rear
1200W Right rear
2500W/1100W Centre
20W GentleHeat

Performance: Hi-light high speed ribbon elements, 2 x Dual elements

Cleaning: Flat easy clean glass surface

Safety: Individual hot surface indicators, Temperature limiters

Controls: Permanent laser etched graphics, Satin chrome control dials

AMP Draw: 36.5A

Supply voltage: 230 - 240

Accessories: N/A

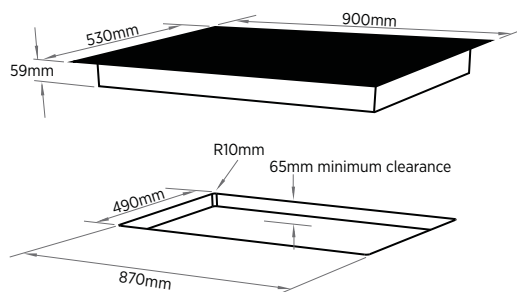

60cm 4 Element Ceramic Hob

CE604CBX1
Ceramic Glass with Stainless Trim
Classic

Dimensions: W600 x D530 x H59 mm

Elements: 4 including 1 dual element

Element ratings: 2200W/750W Left front
1200W Right front
1200W Left rear
1800W Right rear

Performance: Hi-light high speed ribbon elements, Dual element

Cleaning: Flat easy clean glass surface

Safety: Individual hot surface indicators, Temperature limiters

Controls: Permanent laser etched graphics, Satin chrome control dials

AMP Draw: 28A

Supply voltage: 230 - 240

Accessories: N/A

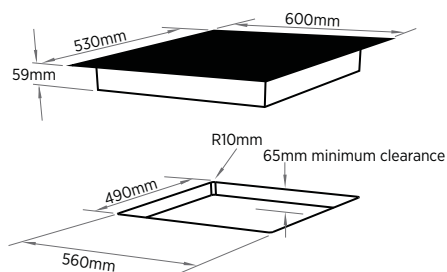

2 YEAR WARRANTY

2 YEAR WARRANTY

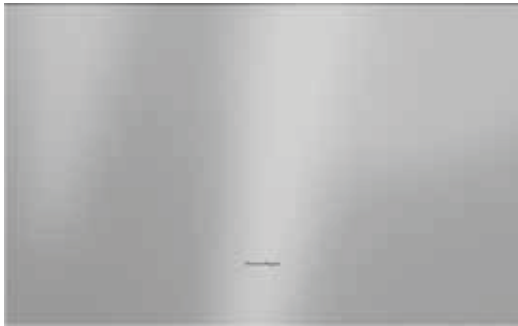

120cm Splashback

SB120X2
Stainless Steel

Dimensions: W1200 x D10 x H750 mm

**2 YEAR
WARRANTY**



90cm Splashback

SB90X2
Stainless Steel

Dimensions: W900 x D10 x H750 mm

**2 YEAR
WARRANTY**



60cm Splashback

SB60X2
Stainless Steel

Dimensions: W600 x D10 x H750 mm

**2 YEAR
WARRANTY**







VENT

Kitchen inspiration doesn't exist in a vacuum, but simple and responsive extraction is always important. Built to perform, our Cooker Hoods effectively capture and eliminate cooking odours, vapour or steam. Each has been designed as the perfect partner products to our Hobs and include sleek black glass with brushed stainless steel to complement any modern kitchen.

Fisher & Paykel



VentSurface Features

VentSurface has been designed to provide a simple and efficient means of removing steam and cooking odours from the kitchen through automatic adjustment.

- 1 Innovative**
Once set to automatic, the clever technology is alert for the need to respond the moment you start cooking.

 - 2 Convenient**
The sheer reflective black glass finish, makes greasy, unsightly filter traps a thing of the past.

 - 3 Responsive**
Clever sensing allows it to constantly adjust to capture and eliminate rising cooking odours, vapour or steam.

 - 4 Efficient**
Perimeter extraction technology creates a high velocity vacuum that is more effective over a wider area than traditional rangehoods and far quieter than conventional technology.

 - 5 Intuitive**
A small range of simple, soft touch buttons gives you control of the technology inside.
-



Cooker Hoods

Banish steam, smoke and lingering smells. Fisher & Paykel Cooker Hoods offer a selection of fan speeds and clever features that quietly and efficiently remove them all.

1 Convenient

An interior, wipeable plate makes cleaning easier (HC120DCXB1, HC90DCXB1, HC90CGX1, HC60DCXB1). Multi-layered filters trap grease effectively. Designed for easy removal, the filters are easy to clean and are dishwasher safe.

2 Responsive

The sleek touch control panel responds to the touch of your finger. Halogen lights provide superb illumination over the entire cooking surface. The dimmable light feature enables you to create the perfect level of light (HC120DCXB1, HC90DCXB1, HC60DCXB1 only).

3 Efficient

Odours can linger in the kitchen well after cooking. The practical timer feature keeps the canopy working for up to fifteen minutes before it automatically turns itself off (HC120DCXB1, HC90DCXB1, HC90CGX1, HC60DCXB1).



Fisher & Paykel





120cm VentSurface Island Canopy
 H1120MXB1 **Kitchen Studio Exclusive**
 Stainless Steel and Black Glass
 Designer

Dimensions: H647 - 892 x W1198 x D650 mm

Fan ratings: 750 M³/hr Max air movement
 61 dBA Max decibel rating

Performance: Perimeter extraction technology, Six fan speeds

Cleaning: Dishwasher safe aluminium mesh filters, Filter cleaning alert

Installation: Two piece adjustable flue with optional extensions, Ducted or recirculating options

Controls: Soft touch controls, Manual and Sensor modes, Timer function, 4 x Halogen lights

Supply voltage: 220 - 240

Optional Accessories: Recirculating kit (part number 791531), Charcoal filter (part number 791474)

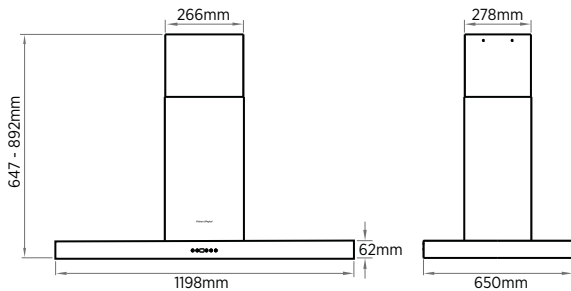

90cm VentSurface Wall Canopy
 HC90MXB1 **Kitchen Studio Exclusive**
 Stainless Steel and Black Glass
 Designer

Dimensions: H682 - 1192 x W898 x D470 mm

Fan ratings: 750 M³/hr Max air movement
 61 dBA Max decibel rating

Performance: Perimeter extraction technology, Six fan speeds

Cleaning: Dishwasher safe aluminium mesh filters, Filter cleaning alert

Installation: Two piece adjustable flue with optional extensions, Ducted or recirculating options

Controls: Soft touch controls, Manual and Sensor modes, Timer function, 2 x Halogen lights

Supply voltage: 220 - 240

Optional Accessories: Recirculating kit (part number 791531), Charcoal filter (part number 791474)

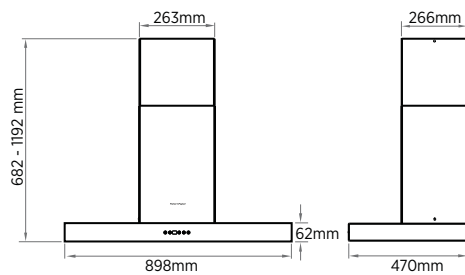

2 YEAR WARRANTY

2 YEAR WARRANTY



120cm Wall Canopy Cooker Hood
 HC120DCXB1
 Stainless Steel and Black Glass
 Designer

Dimensions: H635 - 1035 x W1200 x D500 mm

Fan ratings: 800 M³/hr Max air movement
 60 dBA Max decibel rating

Performance: 3 Fan speeds, Tangential fan

Cleaning: 4 Dishwasher safe aluminium mesh filters,
 Easy-clean interior plate

Installation: Two piece adjustable flue, Ducted, 150mm air outlet,
 Able to be recirculated

Controls: Capacitive touch controls, Timer function,
 2 x 50W Angled halogen lights, Dimmable light control

Supply voltage: 220 - 240

Optional Accessories: Recirculating kit (part number 791820), Charcoal
 filters (part number 791772)

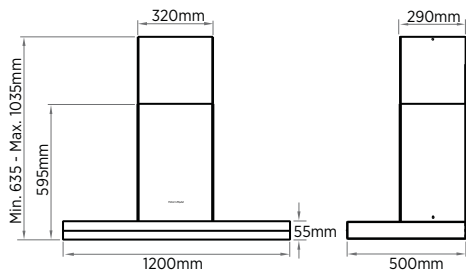

**2 YEAR
 WARRANTY**



90cm Wall Canopy Cooker Hood
 HC90DCXB1
 Stainless Steel and Black Glass
 Designer

Dimensions: H635 - 1035 x W900 x D500 mm

Fan ratings: 800 M³/hr Max air movement
 60 dBA Max decibel rating

Performance: 3 Fan speeds, Tangential fan

Cleaning: 3 Dishwasher safe aluminium mesh filters, Easy-clean
 interior plate

Installation: Two piece adjustable flue, Ducted, 150mm air outlet, Able to
 be recirculated

Controls: Capacitive touch controls, Timer function, 2 x 50W Angled
 halogen lights, Dimmable light control

Supply voltage: 220 - 240

Optional Accessories: Recirculating kit (part number 791820), Charcoal
 filters (part number 791772)

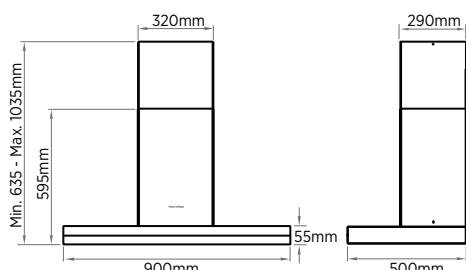

**2 YEAR
 WARRANTY**



60cm Wall Canopy Cooker Hood

HC60DCXB1
Stainless Steel and Black Glass
Designer

Dimensions: H635 - 1035 x W600 x D500 mm

Fan ratings: 800 M³/hr Max air movement
60 dBA Max decibel rating

Performance: 3 Fan speeds, Tangential fan

Cleaning: 2 Dishwasher safe aluminium mesh filters, Easy-clean interior plate

Installation: Two piece adjustable flue, Ducted, 150mm air outlet, Able to be recirculated

Controls: Capacitive touch controls, Timer function, 2 x 50W Angled halogen lights, Dimmable light control

Supply voltage: 220 - 240

Optional Accessories: Recirculating kit (part number 791820), Charcoal filters (part number 791772)

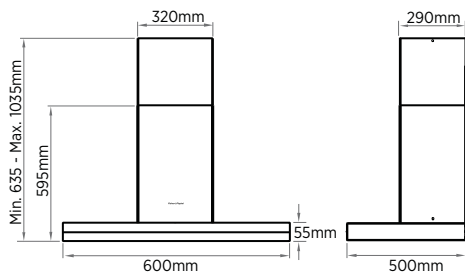

90cm Wall Canopy Cooker Hood

HC90CGX1
Stainless Steel and Clear Glass
Classic

Dimensions: H820 - 1070 x W900 x D500 mm

Fan ratings: 800 M³/hr Max air movement
60 dBA Max decibel rating

Performance: 3 Fan speeds, Tangential fan

Cleaning: 1 Dishwasher safe aluminium mesh filter, Easy-clean interior plate

Installation: Two piece adjustable flue, Ducted, 150mm air outlet, Able to be recirculated

Controls: Soft touch controls, Timer function, 2 x 50W Halogen lights

Supply voltage: 220 - 240

Optional Accessories: Recirculating kit (part number 791820), Charcoal filters (part number 791772)

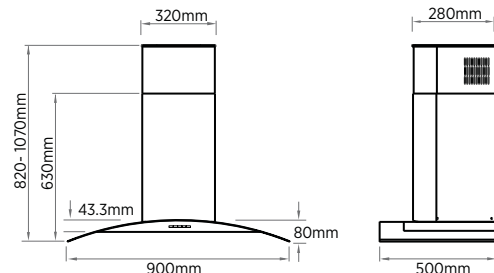

2 YEAR WARRANTY

2 YEAR WARRANTY



90cm Wall Canopy Cooker Hood

EC90IXV1
Stainless Steel
Classic

Dimensions: H1064 x W897 x D528 mm

Fan ratings: 943 M³/hr Max air movement
75 dBA Max decibel rating

Performance: 3 Fan speeds, Tangential fan

Cleaning: 3 Dishwasher safe aluminium mesh filters

Installation: Two piece adjustable flue, Ducted, 150mm air outlet,
Able to be recirculated

Controls: Soft touch controls, 3 x 20W Halogen lights

Supply voltage: 220 - 240

Optional Accessories: Recirculating kit (part number 89504), Charcoal
filters (part number R104165)

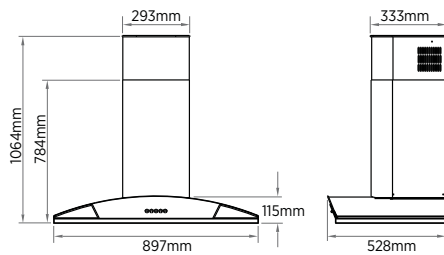

**2 YEAR
WARRANTY**





FREEZER

le chill ❄️

fast freeze
❄️ ❄️ ❄️ ❄️

TEMPERATURE

❄️

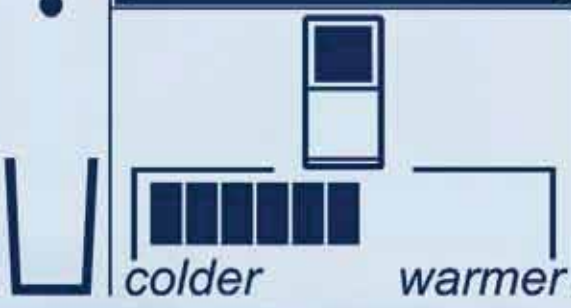

colder *warmer*

ICE

on

SETT



COOL

In any kitchen an even temperament as well as temperature is essential. Technology that adjusts to your needs is our focus. The Active Smart™ range of refrigerators continually adjusts the flow of cold air into your fridge and freezer by sensing daily use and climatic conditions, ensuring that an optimum temperature is always maintained to keep food fresh.

CoolDrawer

The world's first multi-temperature CoolDrawer can be set to freezer, chill, fridge, pantry or wine cooler mode, allowing you to adapt the CoolDrawer to suit your changing lifestyle needs. The convenient drawer design provides flexibility of location, to optimise kitchen and entertainment spaces.

-
- 1 Innovative**
Multi-temperature CoolDrawer is a world first in refrigeration technology.

 - 2 Convenient**
Five temperature settings can be tailored to the needs of your food.

 - 3 Ergonomic**
Easy access at waist-height, with smooth running drawers.

 - 4 Intuitive**
Easy to use electronic interface can change the CoolDrawer temperature at the push of a button.

 - 5 Flexible**
Complements your existing refrigeration and enhances your kitchen design to suit your lifestyle.

 - 6 Precise**
Highly engineered finishing ensures a 4mm clearance between front panels as demanded by professional cabinet-makers.
-





lock



colder



warmer



freezer



chill



fridge



pantry



wine



Active Smart™ Refrigerators

Active Smart™ works with you by sensing how you use the fridge and then adjusting the settings accordingly. A range of luxury features complete the picture.

1 Innovative

Active Smart™ continuously adjusts the flow of cold air into your fridge and freezer by sensing your daily use and climatic conditions, ensuring it maintains optimum temperatures throughout the fridge.

2 Convenient

Includes built-in ice maker and chilled filter water on tap, all with no impact on valuable useable space. A Bottle Chill for when friends drop in unannounced (selected models).

3 Ergonomic

Quality extension runners allow you to fully slide the freezer and vegetable bins in and out, for easy loading and unloading.

4 Intuitive

The Humidity Control System lets you create the perfect 'micro-climate' in each storage bin for specific fruits and vegetables, keeping them fresh for longer.

5 Precise

An optional surround kit for selected models gives the refrigerator a clean, built-in look.

6 Efficient

Alarms on the refrigerator and freezer alert you if the door has been left open.

7 Safe

Secure glass shelving prevents drips and spills falling on the food below.

8 Sabbath mode

Features Fisher & Paykel's Sabbath mode to observe requirements of certain religious faiths.







CoolDrawer

RB90S64MKIW1 Kitchen Studio Exclusive

Integrated

Designer with Designer handle

Optional: EZKleen Stainless Steel door front (part number 840545)

Dimensions: H640 x W855 x D557 mm

Capacity: 80 litres (2.83 cu.ft.) Total
123 litres (4.34 cu.ft.) Gross

Energy rating: A+ (on Refrigerator mode)

Energy usage: 110 kWh per year



Modes:

Chill (-0.5°C): ideal for poultry and fish products



Pantry (12°C): specifically for foods such as tomatoes, bananas, bread and cereals



Wine (7 - 15°C): special settings that preserve and present wine at its optimum temperature



Refrigerator (3°C): ideal storage for most foods, fruits, vegetables, dairy products, processed meats and drinks



Freezer (-18°C): general frozen food storage, with the added flexibility of 3 freezer functions: Bottle chill, Fast freeze, Deep freeze

Features: Touch control glass interface, Key lock, Variable temperature control, Fruit and vegetable drawer, Customisable storage container, Drawer alarm, Sabbath mode

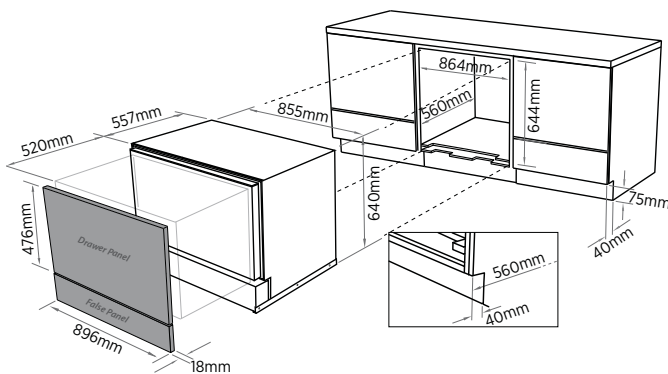

Three Door Ice & Water Refrigerator

RF540ADUX

EZKleen Stainless Steel flat door

Designer with Designer handle

Dimensions: H1780 x W900 x D730 mm

Capacity: 413 litres (14.58 cu.ft.) Refrigerator
128 litres (4.52 cu.ft.) Freezer
541 litres (19.10 cu.ft.) Total

Energy rating: A

Energy usage: 553 kWh per year

Noise level: 43dB

Performance: Active Smart™ system, Frost free freezer, Adaptive defrost, Humidity control system, Humidity control lid, Sabbath mode

Refrigerator: Water dispenser, Door alarm, 3 Adjustable glass shelves, Bottle rack, 6 Half width adjustable door shelves, 2 Covered door shelves, Halogen light, Deli storage area

Freezer: Built-in ice maker, 1 Large plastic bin, 2 Small plastic bins, Ice bin and scoop, Halogen light, Door alarm

Accessories: Water filter (part number 836848)

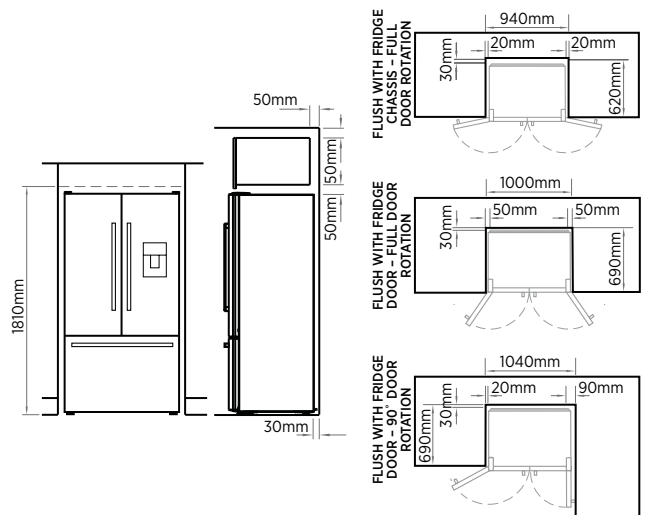

2 YEAR PARTS & LABOUR WARRANTY

2 YEAR PARTS & LABOUR WARRANTY

5 YEAR SEALED SYSTEM PARTS WARRANTY

Ice & Water Refrigerators



Ice & Water Refrigerator
 E522BRXFDU, E522BLXFDU
 EZKleen Stainless Steel flat door
 Designer with Designer handle

Dimensions: H1700 x W790 x D730 mm

Capacity: 351 litres (12.40 cu.ft.) Refrigerator
 118 litres (4.17 cu.ft.) Freezer
 469 litres (16.57 cu.ft.) Total

Energy rating: A
Energy usage: 506 kWh per year

Noise level: 43dB

Performance: Active Smart™ system, Frost free freezer, Adaptive defrost, Humidity control system, Humidity control lid, Sabbath mode

Refrigerator: Water dispenser, Door alarm, 4 Adjustable glass shelves, Bottle rack, 2 Full width adjustable door shelves, 2 Half width adjustable door shelves, 2 Covered door shelves, 2 Egg trays, Halogen light

Freezer: Built-in ice maker, 1 Large plastic bin, 2 Small plastic bins, Ice bin and scoop, 1 Centre roll out tray, Door alarm

Accessories: Water filter (part number 836848)

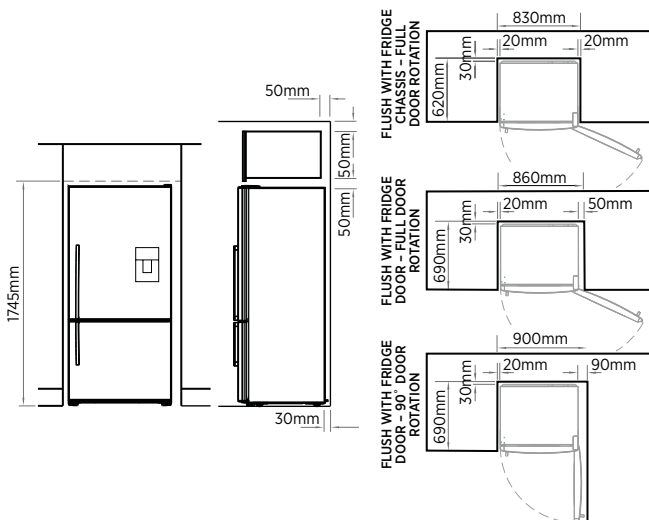

2 YEAR PARTS & LABOUR WARRANTY

5 YEAR SEALED SYSTEM PARTS WARRANTY



Ice & Water Refrigerator
 E442BRXFDU
 EZKleen Stainless Steel flat door
 Designer with Designer handle

Dimensions: H1700 x W680 x D730 mm

Capacity: 295 litres (10.41 cu.ft.) Refrigerator
 97 litres (3.43 cu.ft.) Freezer
 392 litres (13.84 cu.ft.) Total

Energy rating: A
Energy usage: 450 kWh per year

Noise level: 43dB

Performance: Active Smart™ system, Frost free freezer, Adaptive defrost, Humidity control system, Humidity control lid, Sabbath mode

Refrigerator: Water dispenser, Door alarm, 4 Adjustable glass shelves, Bottle rack, 2 Full width adjustable door shelves, 2 Half width adjustable door shelves, 2 Covered door shelves, 2 Egg trays, Halogen light

Freezer: Built-in ice maker, 1 Large plastic bin, 2 Small plastic bins, Ice bin and scoop, 1 Centre roll out tray, Door alarm

Accessories: Water filter (part number 836848)

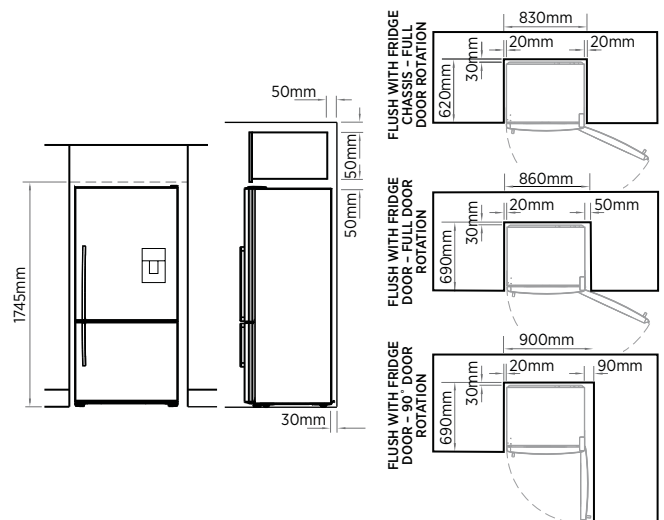

2 YEAR PARTS & LABOUR WARRANTY

5 YEAR SEALED SYSTEM PARTS WARRANTY



Ice & Water Refrigerator

E402BRXFDU
EZKleen Stainless Steel flat door
Designer with Designer handle

Dimensions: H1700 x W635 x D730 mm

Capacity: 272 litres (9.61 cu.ft.) Refrigerator
88 litres (3.11 cu.ft.) Freezer
360 litres (12.72 cu.ft.) Total

Energy rating: A
Energy usage: 425 kWh per year

Noise level: 42dB

Performance: Active Smart™ system, Frost free freezer, Adaptive defrost, Humidity control system, Humidity control lid, Sabbath mode

Refrigerator: Water dispenser, Door alarm, 4 Adjustable glass shelves, Bottle rack, 2 Full width adjustable door shelves, 2 Half width adjustable door shelves, 2 Covered door shelves, 2 Egg trays, Halogen light

Freezer: Built-in ice maker, 1 Large plastic bin, 2 Small plastic bins, Ice bin and scoop, 1 Centre roll out tray, Door alarm

Accessories: Water filter (part number 836848)

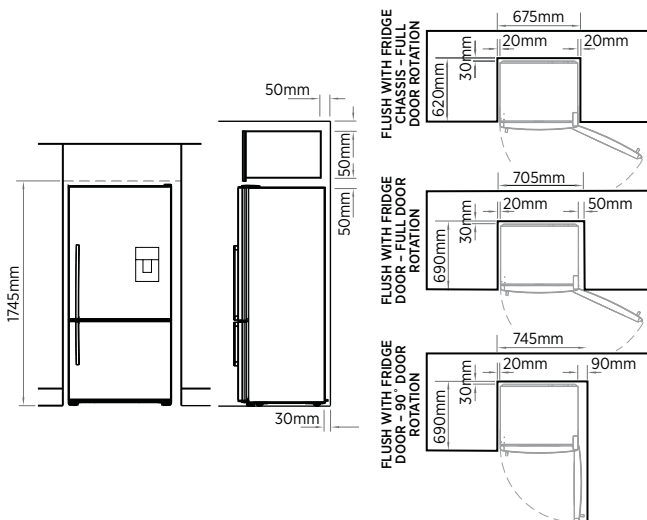

2 YEAR PARTS & LABOUR WARRANTY

5 YEAR SEALED SYSTEM PARTS WARRANTY



Ice & Water Refrigerator

E522BRXU
EZKleen Stainless Steel curved door
Classic with Flat Curved handle

Dimensions: H1700 x W790 x D736 mm

Capacity: 351 litres (12.40 cu.ft.) Refrigerator
118 litres (4.17 cu.ft.) Freezer
469 litres (16.57 cu.ft.) Total

Energy Rating: A
Energy Usage: 506 kWh per year

Noise level: 43dB

Performance: Active Smart™ system, Frost free freezer, Adaptive defrost, Humidity control system, Humidity control lid, Sabbath mode

Refrigerator: Water dispenser, Door alarm, 4 Adjustable glass shelves, Bottle rack, 2 Full width adjustable door shelves, 2 Half width adjustable door shelves, 2 Covered door shelves, 2 Egg trays, Halogen light

Freezer: Built-in ice maker, 1 Large plastic bin, 2 Small plastic bins, Ice bin and scoop, 1 Centre roll out tray, Door alarm

Accessories: Water filter (part number 836848)

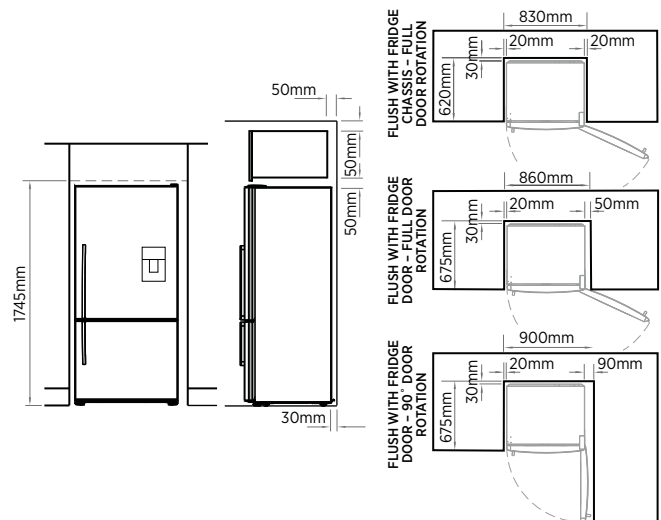

2 YEAR PARTS & LABOUR WARRANTY

5 YEAR SEALED SYSTEM PARTS WARRANTY



Bottom Mount Refrigerator
 E522BRXFD, E522BLXFD
 EZKleen Stainless Steel flat door
 Designer with Designer handle

Dimensions: H1695 x W790 x D730 mm

Capacity: 352 litres (12.40 cu.ft.) Refrigerator
 121 litres (4.27 cu.ft.) Freezer
 473 litres (16.67 cu.ft.) Total

Energy Rating: A
Energy Usage: 510 kWh per year

Noise level: 43dB

Performance: Active Smart™ system, Frost free freezer, Adaptive defrost, Humidity control system, Humidity control lid

Refrigerator: Door alarm, 4 Adjustable glass shelves, Bottle rack, 2 Full width adjustable door shelves, 2 Half width adjustable door shelves, 2 Covered door shelves, 2 Egg trays, Halogen light

Freezer: 1 Large plastic bin, 2 Small plastic bins, 2 Ice trays, 1 Centre roll out tray, Door alarm

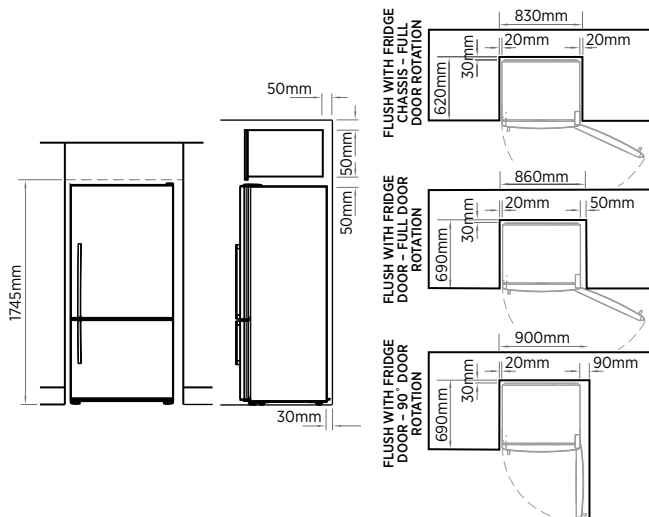

2 YEAR PARTS & LABOUR WARRANTY

5 YEAR SEALED SYSTEM PARTS WARRANTY



Bottom Mount Refrigerator
 E442BRXFD, E442BLXFD
 EZKleen Stainless Steel flat door
 Designer with Designer handle

Dimensions: H1695 x W680 x D730 mm

Capacity: 296 litres (10.45 cu.ft.) Refrigerator
 100 litres (3.53 cu.ft.) Freezer
 396 litres (13.98 cu.ft.) Total

Energy Rating: A
Energy Usage: 453 kWh per year

Noise level: 43dB

Performance: Active Smart™ system, Frost free freezer, Adaptive defrost, Humidity control system, Humidity control lid

Refrigerator: Door alarm, 4 Adjustable glass shelves, Bottle rack, 2 Full width adjustable door shelves, 2 Half width adjustable door shelves, 2 Covered door shelves, 2 Egg trays, Halogen light

Freezer: 1 Large plastic bin, 2 Small plastic bins, 2 Ice trays, 1 Centre roll out tray, Door alarm

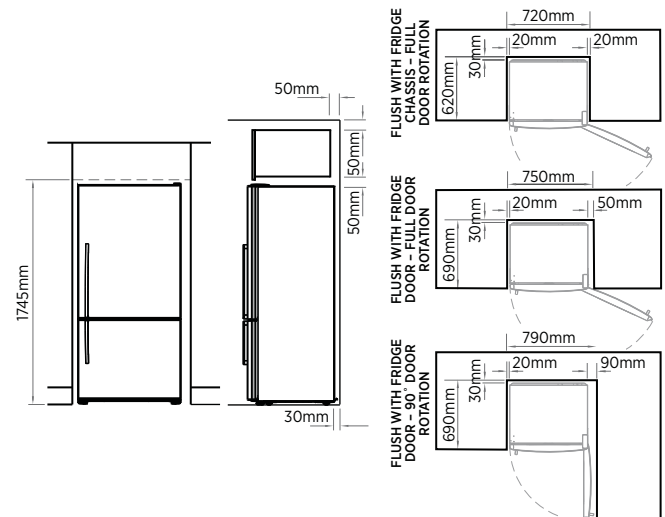

2 YEAR PARTS & LABOUR WARRANTY

5 YEAR SEALED SYSTEM PARTS WARRANTY



Bottom Mount Refrigerator
 E402BRXFD, E402BLXFD
 EZKleen Stainless Steel flat door
 Designer with Designer handle

Dimensions: H1695 x W635 x D730 mm

Capacity: 273 litres (9.64 cu.ft.) Refrigerator
 91 litres (3.21 cu.ft.) Freezer
 364 litres (12.85 cu.ft.) Total

Energy rating: A
Energy usage: 430 kWh per year

Noise level: 42dB

Performance: Active Smart™ system, Frost free freezer, Adaptive defrost, Humidity control system, Humidity control lid

Refrigerator: Door alarm, 4 Adjustable glass shelves, Bottle rack, 2 Full width adjustable door shelves, 2 Half width adjustable door shelves, 2 Covered door shelves, 2 Egg trays, Halogen light

Freezer: 1 Large plastic bin, 2 Small plastic bins, 2 Ice trays, 1 Centre roll out tray, Door alarm

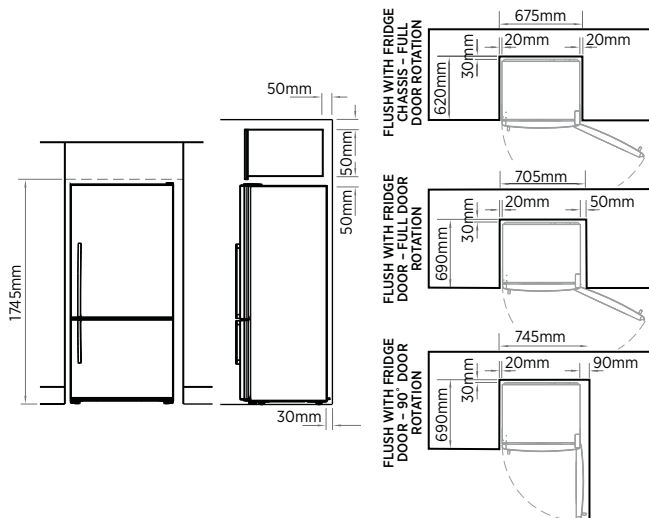

2 YEAR PARTS & LABOUR WARRANTY

5 YEAR SEALED SYSTEM PARTS WARRANTY



Bottom Mount Refrigerator
 E552BRX, E552BLX
 EZKleen Stainless Steel curved door
 Classic with Curved handle

Dimensions: H1695 x W790 x D736 mm

Capacity: 352 litres (12.40 cu.ft.) Refrigerator
 121 litres (4.27 cu.ft.) Freezer
 473 litres (16.67 cu.ft.) Total

Energy rating: A
Energy usage: 510 kWh per year

Noise level: 43dB

Performance: Active Smart™ system, Frost free freezer, Adaptive defrost, Humidity control system, Humidity control lid

Refrigerator: Door alarm, 4 Adjustable glass shelves, Bottle rack, 2 Full width adjustable door shelves, 2 Half width adjustable door shelves, 2 Covered door shelves, 2 Egg trays, Halogen light

Freezer: 1 Large plastic bin, 2 Small plastic bins, 2 Ice trays, 1 Centre roll out tray, Door alarm

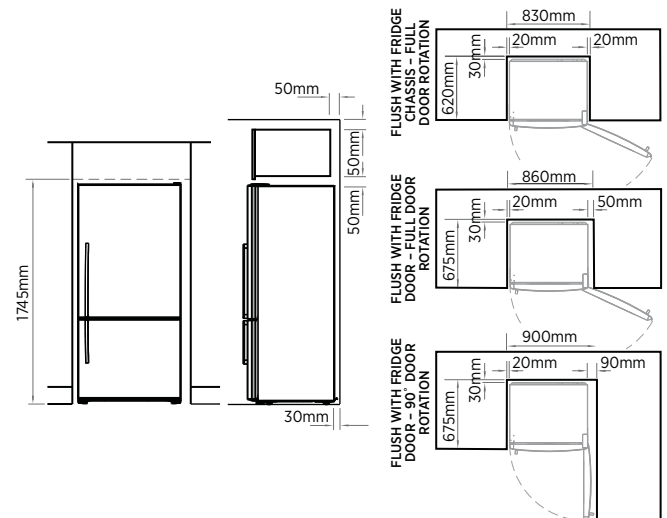

2 YEAR PARTS & LABOUR WARRANTY

5 YEAR SEALED SYSTEM PARTS WARRANTY



Bottom Mount Refrigerator

E442BRX, E442BLX
EZKleen Stainless Steel curved door
Classic with Curved handle

Dimensions: H1695 x W680 x D736 mm

Capacity: 296 litres (10.45 cu.ft.) Refrigerator
100 litres (3.53 cu.ft.) Freezer
396 litres (13.98 cu.ft.) Total

Energy rating: A
Energy usage: 453 kWh per year

Noise level: 43dB

Performance: Active Smart™ system, Frost free freezer, Adaptive defrost, Humidity control system, Humidity control lid

Refrigerator: Door alarm, 4 Adjustable glass shelves, Bottle rack, 2 Full width adjustable door shelves, 2 Half width adjustable door shelves, 2 Covered door shelves, 2 Egg trays, Halogen light

Freezer: 1 Large plastic bin, 2 Small plastic bins, 2 Ice trays, 1 Centre roll out tray, Door alarm



Bottom Mount Refrigerator

E402BRX, E402BLX
EZKleen Stainless Steel curved door
Classic with Curved handle

Dimensions: H1695 x W635 x D736 mm

Capacity: 273 litres (9.64 cu.ft.) Refrigerator
91 litres (3.21 cu.ft.) Freezer
364 litres (12.85 cu.ft.) Total

Energy Rating: A
Energy Usage: 430 kWh per year

Noise level: 42dB

Performance: Active Smart™ system, Frost free freezer, Adaptive defrost, Humidity control system, Humidity control lid

Refrigerator: Door alarm, 4 Adjustable glass shelves, Bottle rack, 2 Full width adjustable door shelves, 2 Half width adjustable door shelves, 2 Covered door shelves, 2 Egg trays, Halogen light

Freezer: 1 Large plastic bin, 2 Small plastic bins, 2 Ice trays, 1 Centre roll out tray, Door alarm

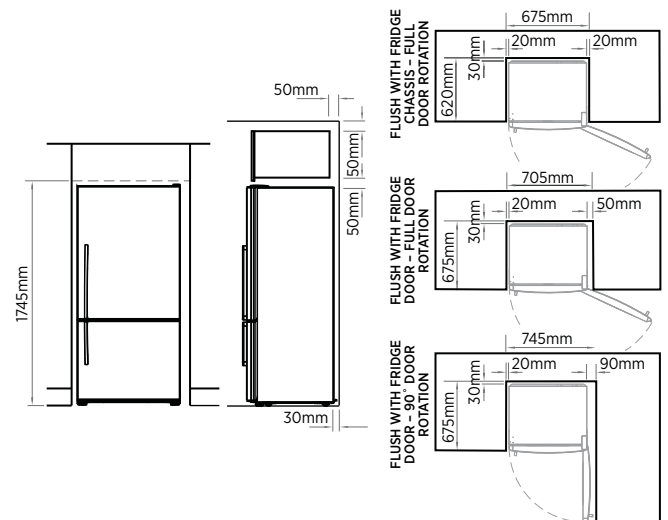
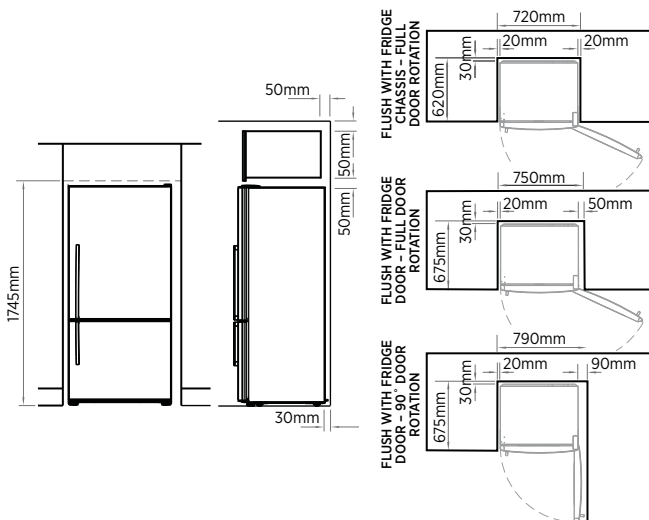

2 YEAR PARTS & LABOUR WARRANTY

5 YEAR SEALED SYSTEM PARTS WARRANTY

2 YEAR PARTS & LABOUR WARRANTY

5 YEAR SEALED SYSTEM PARTS WARRANTY



Top Mount Refrigerator

E52ITRX, E52ITLX
EZKleen Stainless Steel curved door
Classic with Curved handle

Dimensions: H1695 x W790 x D736 mm

Capacity: 390 litres (13.77 cu.ft.) Refrigerator
97 litres (3.43 cu.ft.) Freezer
487 litres (17.20 cu.ft.) Total

Energy Rating: A
Energy Usage: 445 kWh per year

Noise level: 43dB

Performance: Active Smart™ system, Frost free freezer, Adaptive defrost, Humidity control system, Humidity control lid

Refrigerator: Door alarm, 4 Adjustable glass shelves, Bottle rack, 2 Full width adjustable door shelves, 2 Half width adjustable door shelves, 2 Covered door shelves, 2 Egg trays, Halogen light

Freezer: 2 Ice trays, Door alarm, 1 Glass shelf, 3 Door pockets

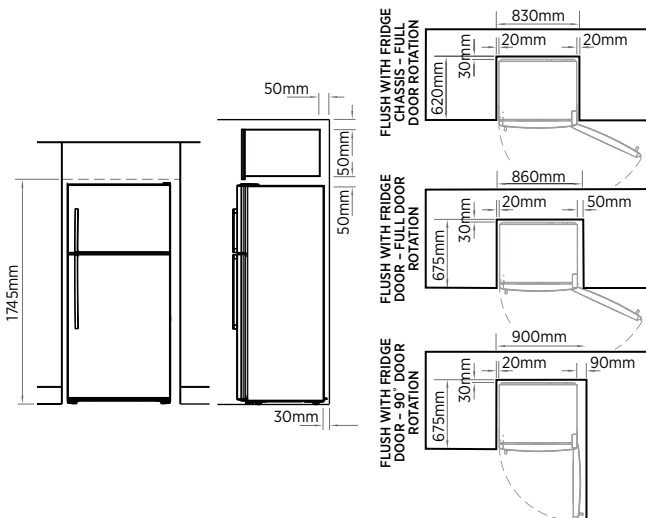

2 YEAR PARTS & LABOUR WARRANTY

5 YEAR SEALED SYSTEM PARTS WARRANTY



Bottom Mount Refrigerator

RF342BCRX1 (Right hand only)
EZKleen Stainless Steel curved door
Classic with Curved handle

Dimensions: H1880 x W600 x D670 mm

Capacity: 230 litres (8.12 cu.ft.) Refrigerator
80 litres (2.83 cu.ft.) Freezer
310 litres (10.95 cu.ft.) Total

Energy Rating: A+
Energy Usage: 319 kWh per year

Noise level: 42dB

Performance: Max cool, Cool storage drawer, Humidity controlled drawer, Holiday mode, Frost free, Fast freeze

Refrigerator: Door alarm, Interlocking adjustable glass shelves, Dairy compartment, Deodoriser

Freezer: Door alarm, 2 Large bins, 1 Half depth bin, 1 Ice tray, 2 Shallow bins

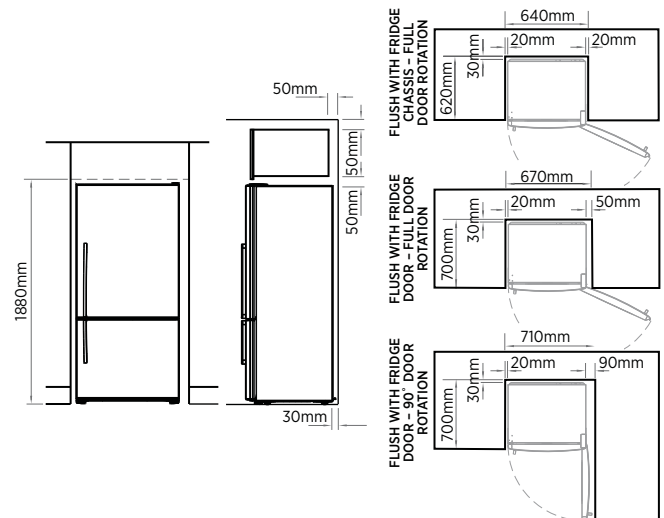

2 YEAR PARTS & LABOUR WARRANTY

Surround Kit



Stainless Steel Surround Kit
RF540ADUX

Allows you to build your refrigerator into your kitchen cabinetry to give it an integrated look.

Part No. 818763

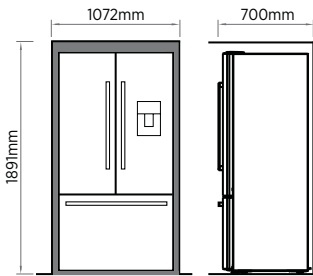

Stainless Steel Surround Kit
E522 + E522

Allows you to build your refrigerator into your kitchen cabinetry to give it an integrated look.

Part No. 818759

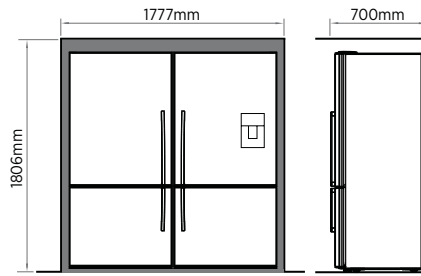

Stainless Steel Surround Kit
E442 + E442

Allows you to build your refrigerator into your kitchen cabinetry to give it an integrated look.

Part No. 818760

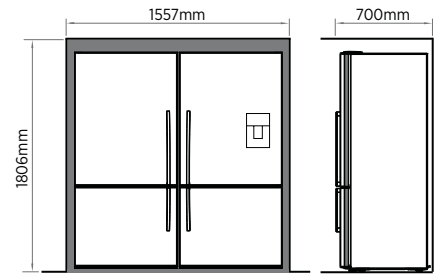

Stainless Steel Surround Kit
E402 + E402

Allows you to build your refrigerator into your kitchen cabinetry to give it an integrated look.

Part No. 818761

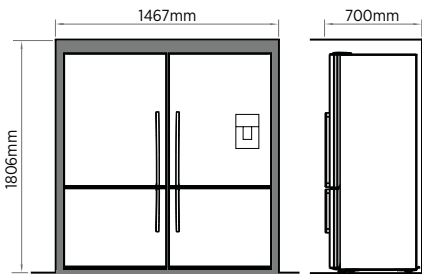

Stainless Steel Surround Kit
E522, E521 Right hand

Allows you to build your refrigerator into your kitchen cabinetry to give it an integrated look.

Part No. 818762

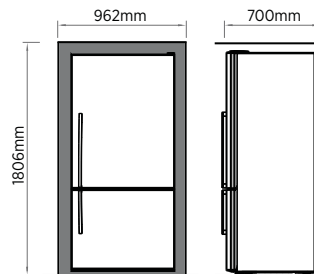

Stainless Steel Surround Kit
E522, E521 Left hand

Allows you to build your refrigerator into your kitchen cabinetry to give it an integrated look.

Part No. 818758

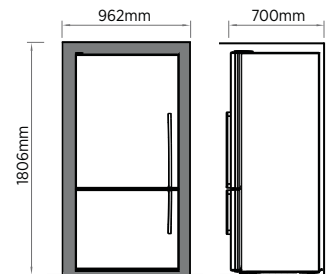

Note: Please refer to Surround Kit Installation Sheet for installation directions.

Additional accessories can be purchased through your Fisher & Paykel dealer or through Fisher & Paykel Customer Care Tel 0845 0662200.

72 Joiner Kit



Joiner Kit

E522, E442, E402

Joiner Kit may need to be trimmed for smaller refrigeration pairs.

Provides a seamless join between the refrigerators.

Part No. 819264 (Silver)

Additional accessories can be purchased through your Fisher & Paykel dealer or through Fisher & Paykel Customer Care Tel 0845 0662200.

E522 + E522

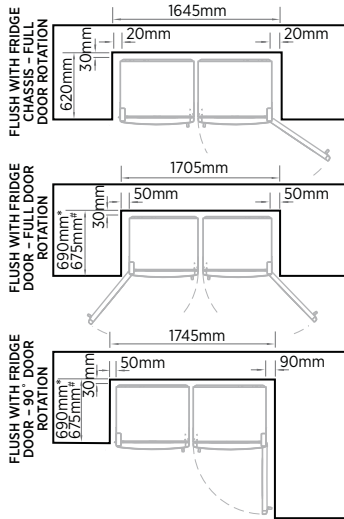
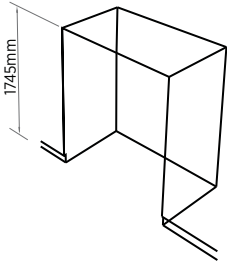

* Flat door
Curved door

E522 + E442

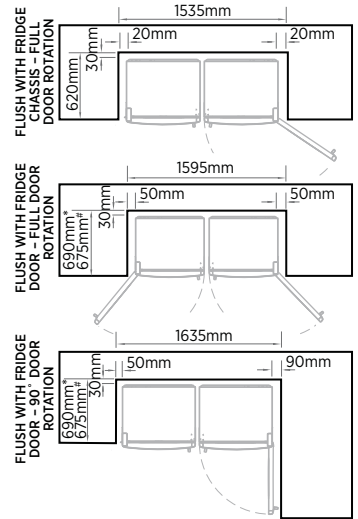
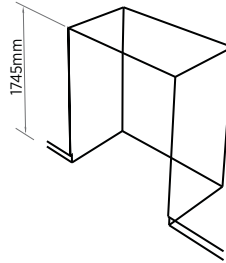

* Flat door
Curved door

E522 + E402

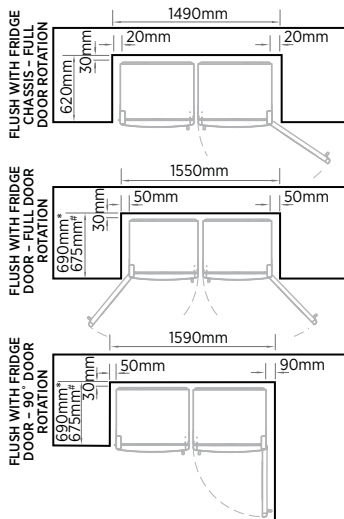
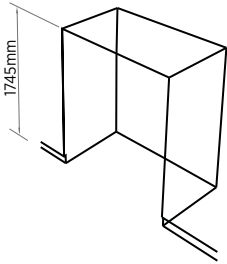

* Flat door
Curved door

E442 + E442

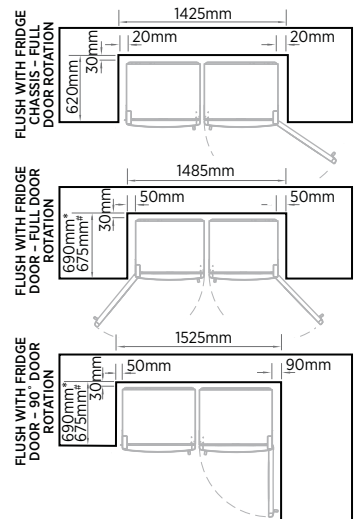
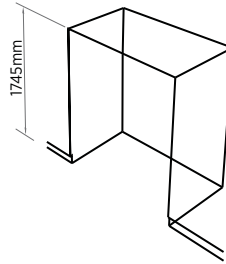

* Flat door
Curved door

E442 + E402

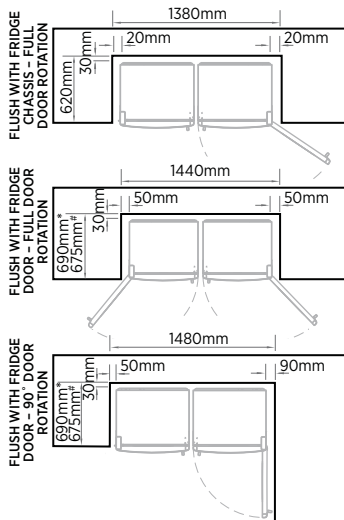
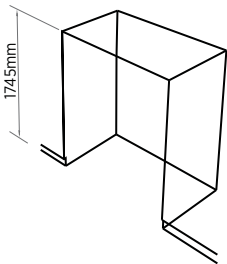

* Flat door
Curved door

E402 + E402

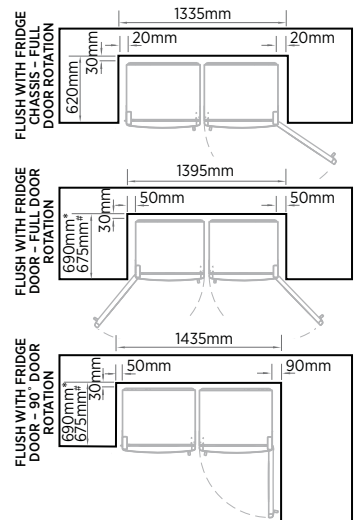
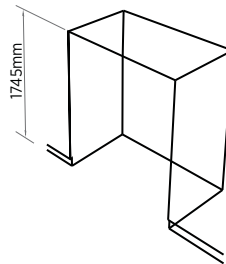

* Flat door
Curved door







Fisher & Paykel

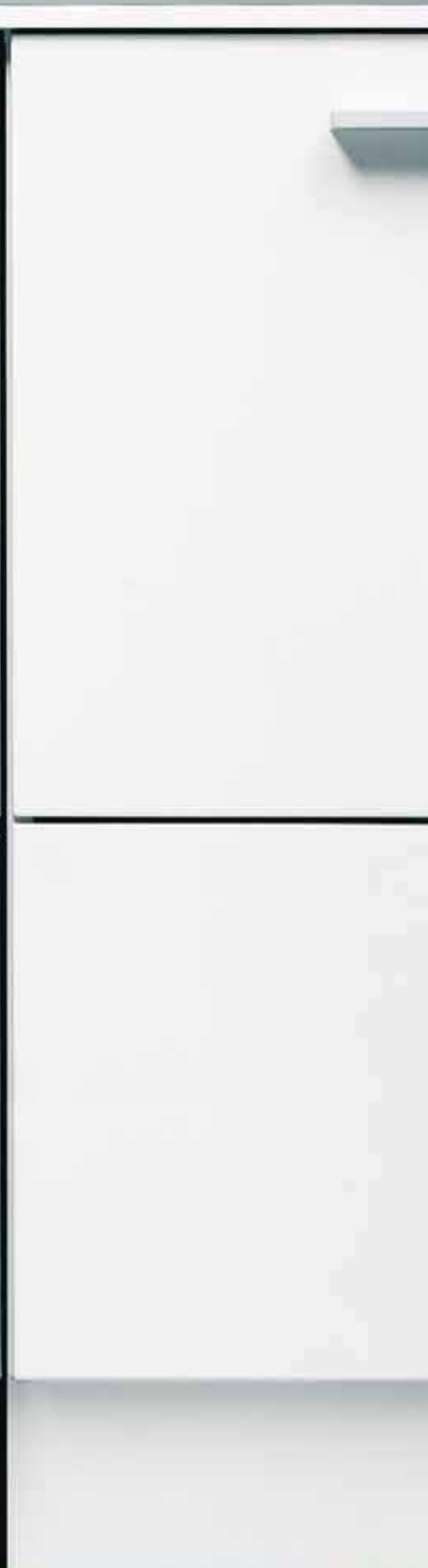

CLEAN

Why shouldn't cleaning up be as enjoyable as cooking itself? The DishDrawer® range is designed to make life easy. Wide, tall, double and single drawer options allow you to choose the combination that works for your lifestyle. The range can easily be concealed behind kitchen cabinetry to seamlessly blend in with your kitchen and the ergonomic design requires less movement to open, load and close — minimising bending. There is also a selection of conventional dishwashers to complement the range.



DishDrawer® Wide

A simple solution for entertainers and large families, the DishDrawer® Wide is an enlarged version of the standard DishDrawer®. At 90cm wide it accommodates nine place settings, has fully adjustable racking and the tub design easily fits large platters, chopping boards, pans and roasting dishes. Also available in an integrated model that blends in with your kitchen cabinetry.

- 1 Innovative**
Before washing begins, detergent goes through the world's first flow through dispenser to ensure it is thoroughly dissolved, providing a faster, more hygienic wash with no hint of detergent burn.
- 2 Convenient**
Taller than the standard DishDrawer® so you can fit large plates up to 31.5cm in diameter. Racking is designed to hold long utensils and can fold away to free up space.
- 3 Ergonomic**
As easy to open and close as a kitchen drawer, loading and unloading requires minimal bending. Easy-to-use folding tines allow you to place large pots, platters and bowls into the drawer with ease.
- 4 Efficient**
A choice of nine wash programmes, including an Eco option to minimise water and energy usage.
- 5 Safe**
Includes a key lock and child safety lock.
- 6 Eco friendly**
AAA rated for energy efficiency, cleaning and drying performance.





DishDrawer®

We created the DishDrawer® over a decade ago and revolutionised the way we cleaned our dishes. We continue to design ergonomically superior DishDrawer®s that require less movement to open, load and close and require no bending. We have also found new ways to make dishwashing even easier by increasing the height of the drawer to allow for even larger plates and platters.

-
- 1 Innovative**
World first design and configuration.

 - 2 Convenient**
The double DishDrawer® lets the user match the wash programme to the exact load type in each drawer.

 - 3 Ergonomic**
As easy to open and close as a kitchen drawer, loading and unloading requires minimal bending. Easy-to-use folding tines allow you to place large pots, platters and bowls into the drawer with ease.
Single drawers can be placed in the most convenient locations, minimising unnecessary bending.

 - 4 Intuitive**
Before washing begins, detergent goes through the world's first flow through dispenser to ensure it is thoroughly dissolved, providing a faster, more hygienic wash with no hint of detergent burn.

 - 5 Efficient**
A choice of nine wash programmes, including an Eco option to minimise water and energy usage.

 - 6 Safe**
Includes a key lock and child safety lock.

 - 7 Eco friendly**
AAA rated for energy efficiency, cleaning and drying performance.
-





Friden's Playket



DishDrawer® Wide
 DD90SDFHTX1 **Kitchen Studio Exclusive**
 EZKleen Stainless Steel
 Designer

Dimensions: H478 x W895 x D571 mm

Energy rating*: AAA

Noise level: 48 dB

Performance: Smart Drive™ intelligent technology, Intelligent load sensing for optimum performance, Flow through detergent dispenser, Quiet operation

Capacity and loading: 9 Place settings, Flexible racking system, Fold down tines, Adjustable racks and cup racks, Accommodates long stemmed wine glasses, Accommodates plates up to 31.5cm

Wash programmes: 9 wash programmes, Eco options, Permanent memory of the last cycle used

Safety: Three stage total flood protection

Controls: Easy to use, primary and secondary (concealed) control panels with single touch programming, Key lock, Child lock, End of cycle beeps, One button start, Delay start option up to 12 hours, Rinse aid indicator light and lens, Electronic fault/Diagnostic indicator

AMP Draw: 10A

Accessories: Cutlery basket, Knife clip, Multi purpose clip

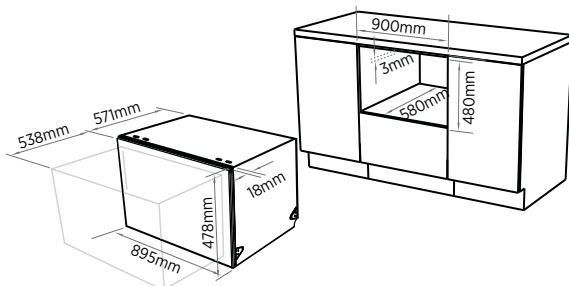

2 YEAR WARRANTY

* Tested to European Standard EN50242

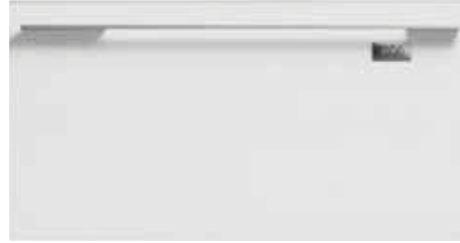

DishDrawer® Wide
 DD90SHTII **Kitchen Studio Exclusive**
 Integrated (apply your own cabinetry facade)
 Designer

Dimensions: H478 x W895 x D571 mm

Energy rating*: AAA

Noise level: 48 dB

Performance: Smart Drive™ intelligent technology, Intelligent load sensing for optimum performance, Flow through detergent dispenser, Quiet operation

Capacity and loading: 9 Place settings, Flexible racking system, Fold down tines, Adjustable racks and cup racks, Accommodates long stemmed wine glasses, Accommodates plates up to 31.5cm

Wash programmes: 9 wash programmes, Eco options, Permanent memory of the last cycle used

Safety: Three stage total flood protection

Controls: Easy to use, primary and secondary (concealed) control panels with single touch programming, Key lock, Child lock, End of cycle beeps, One button start, Delay start option up to 12 hours, Rinse aid indicator light and lens, Electronic fault/Diagnostic indicator

AMP Draw: 10A

Accessories: Cutlery basket, Knife clip, Multi purpose clip, Satin Chrome Rectangular Badge

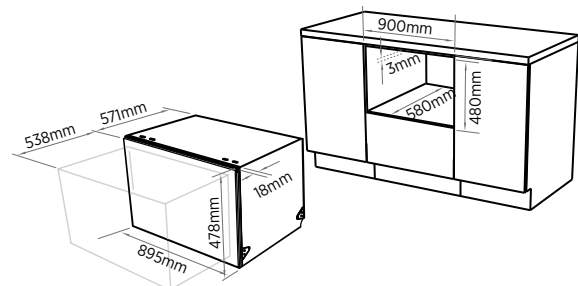

2 YEAR WARRANTY

* Tested to European Standard EN50242

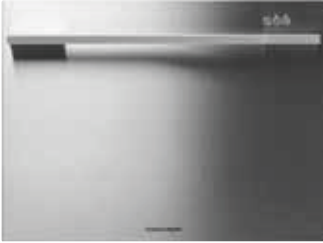

DishDrawer® Tall
DD60SDFHTX6 **Kitchen Studio Exclusive**
EZKleen Stainless Steel
Designer

Dimensions: H477 x W599 x D570 mm

Energy rating*: AAA

Noise level: 44.5 dB

Performance: Smart Drive™ intelligent technology, Intelligent load sensing for optimum performance, Flow through detergent dispenser, Quiet operation

Capacity and loading: 6 Place settings, Flexible racking system, Fold down tines, Adjustable racks and cup racks, Accommodates long stemmed wine glasses, Accommodates plates up to 33cm

Wash programmes: 9 wash programmes, Eco options, Permanent memory of the last cycle used

Safety: Three stage total flood protection

Controls: Easy to use primary and secondary concealed control panels with single touch programming, Key lock, Child lock, End of cycle beeps, One button start, Energy saving delay start option up to 12 hours, Rinse aid indicator light and lens, Electronic fault/Diagnostic indicator

AMP Draw: 5A Minimum

Accessories: Cutlery basket

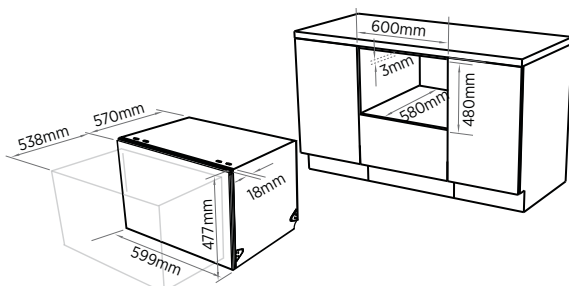

2 YEAR
WARRANTY

* Tested to European Standard EN50242



DishDrawer® Tall
DD60SHTI6 **Kitchen Studio Exclusive**
Integrated (apply your own cabinetry facade)
Designer

Dimensions: H453 - 477 x W599 x D570 mm

Energy rating*: AAA

Noise level: 44.5 dB

Performance: Smart Drive™ intelligent technology, Intelligent load sensing for optimum performance, Flow through detergent dispenser, Quiet operation

Capacity and loading: 6 Place settings, Flexible racking system, Fold down tines, Adjustable racks and cup racks, Accommodates long stemmed wine glasses, Accommodates plates up to 33cm

Wash programmes: 9 wash programmes, Eco options, Permanent memory of the last cycle used

Safety: Three stage total flood protection

Controls: Easy to use, primary and secondary concealed control panels with single touch programming, Key lock, Child lock, End of cycle beeps, One button start, Energy saving delay start option up to 12 hours, Rinse aid indicator light and lens, Electronic fault/Diagnostic indicator

AMP Draw: 5A Minimum

Accessories: Cutlery basket, Satin Chrome Rectangular Badge

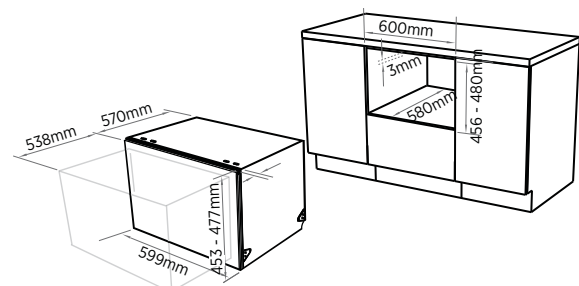

2 YEAR
WARRANTY

* Tested to European Standard EN50242



Double DishDrawer®
DD60DDFHX6
EZKleen Stainless Steel
Designer

Dimensions: H819.5 – 879.5 x W599 x D570 mm

Energy rating*: AAA

Noise level: Top drawer 44.5 dB

Performance: Smart Drive™ intelligent technology, Intelligent load sensing for optimum performance, Flow through detergent dispenser, Quiet operation

Capacity and loading: 6 Place settings per drawer, Flexible racking system, Fold down tines, Adjustable racks and cup racks, Accommodates long stemmed wine glasses, Accommodates plates up to 29cm

Wash programmes: 9 wash programmes, Genuine half load wash option, Eco options, Permanent memory of the last cycle used

Safety: Three stage total flood protection

Controls: Easy to use primary and secondary concealed control panels with single touch programming, Key lock, Child lock, End of cycle beeps, One button start, Energy saving delay start option up to 12 hours, Rinse aid indicator light and lens, Electronic fault/Diagnostic indicator

AMP Draw: 10A

Accessories: Cutlery basket, Kickstrip

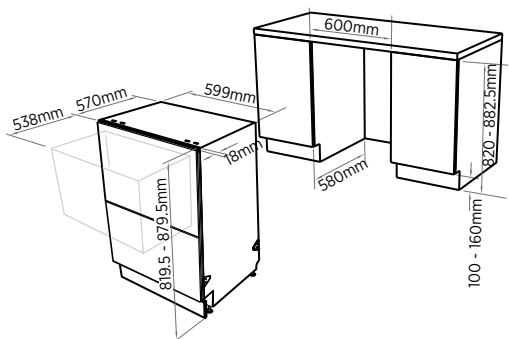

* Tested to European Standard EN50242

2 YEAR WARRANTY



Double DishDrawer®
DD60DHI6
Integrated (apply your own cabinetry facade)
Designer

Dimensions: H819.5 – 879.5 x W599 x D570 mm

Energy rating*: AAA

Noise level: Top drawer 44.5 dB

Performance: Smart Drive™ intelligent technology, Intelligent load sensing for optimum performance, Flow through detergent dispenser, Quiet operation

Capacity and loading: 6 Place settings per drawer, Flexible racking system, Fold down tines, Adjustable racks and cup racks, Accommodates long stemmed wine glasses, Accommodates plates up to 29cm

Wash programmes: 9 wash programmes, Genuine half load wash option, Eco options, Permanent memory of the last cycle used

Safety: Three stage total flood protection

Controls: Easy to use primary and secondary concealed control panels with single touch programming, Key lock, Child lock, End of cycle beeps, One button start, Energy saving delay start option up to 12 hours, Rinse aid indicator light and lens, Electronic fault/Diagnostic indicator

AMP Draw: 10A

Accessories: Cutlery basket, Kickstrip, 2x Satin Chrome Rectangular Badges

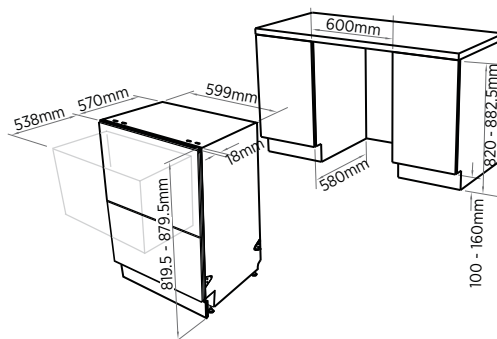

* Tested to European Standard EN50242

2 YEAR WARRANTY



Double DishDrawer®
DD60DCHX6
EZKleen Stainless Steel
Classic

Dimensions: H819.5 – 879.5 x W599 x D570 mm

Energy rating*: AAA

Noise level: Top drawer 44.5 dB

Performance: Smart Drive™ intelligent technology, Intelligent load sensing for optimum performance, Flow through detergent dispenser, Quiet operation

Capacity and loading: 6 Place settings per drawer, Flexible racking system, Fold down tines, Adjustable racks and cup racks, Accommodates long stemmed wine glasses, Accommodates plates up to 29cm

Wash programmes: 9 wash programmes, Genuine half load wash option, Eco options, Permanent memory of the last cycle used

Safety: Three stage total flood protection

Controls: Wash progress and time remaining display, Digital display, Easy to use primary and secondary concealed control panels with single touch programming, Key lock, Child lock, End of cycle beeps, One button start, Energy saving delay start option up to 12 hours, Rinse aid indicator light and lens, Electronic fault/Diagnostic indicator

AMP Draw: 10A

Accessories: Cutlery basket, Kickstrip

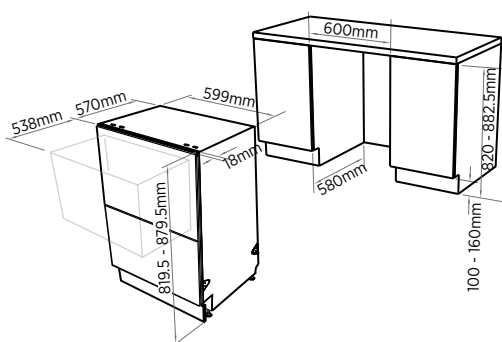

* Tested to European Standard EN50242

**2 YEAR
WARRANTY**



Double DishDrawer®
DD60DCHB6
Black
Classic

Dimensions: H819.5 – 879.5 x W599 x D570 mm

Energy rating*: AAA

Noise level: Top drawer 44.5 dB

Performance: Smart Drive™ intelligent technology, Intelligent load sensing for optimum performance, Flow through detergent dispenser, Quiet operation

Capacity and loading: 6 Place settings per drawer, Flexible racking system, Fold down tines, Adjustable racks and cup racks, Accommodates long stemmed wine glasses, Accommodates plates up to 29cm

Wash programmes: 9 wash programmes, Genuine half load wash option, Eco options, Permanent memory of the last cycle used

Safety: Three stage total flood protection

Controls: Wash progress and time remaining display, Digital display, Easy to use primary and secondary concealed control panels with single touch programming, Key lock, Child lock, End of cycle beeps, One button start, Energy saving delay start option up to 12 hours, Rinse aid indicator light and lens, Electronic fault/Diagnostic indicator

AMP Draw: 10A

Accessories: Cutlery basket, Kickstrip

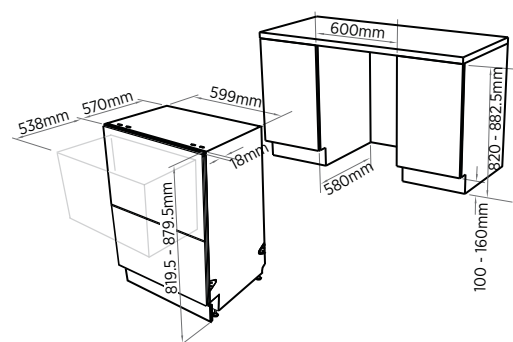

* Tested to European Standard EN50242

**2 YEAR
WARRANTY**



Double DishDrawer®

DD60DCHW6
White
Classic

Dimensions: H819.5 – 879.5 x W599 x D570 mm

Energy rating*: AAA

Noise level: Top drawer 44.5 dB

Performance: Smart Drive™ intelligent technology, Intelligent load sensing for optimum performance, Flow through detergent dispenser, Quiet operation

Capacity and loading: 6 Place settings per drawer, Flexible racking system, Fold down tines, Adjustable racks and cup racks, Accommodates long stemmed wine glasses, Accommodates plates up to 29cm

Wash programmes: 9 wash programmes, Genuine half load wash option, Eco options, Permanent memory of the last cycle used

Safety: Three stage total flood protection

Controls: Wash progress and time remaining display, Digital display, Easy to use primary and secondary concealed control panels with single touch programming, Key lock, Child lock, End of cycle beeps, One button start, Energy saving delay start option up to 12 hours, Rinse aid indicator light and lens, Electronic fault/Diagnostic indicator

AMP Draw: 10A

Accessories: Cutlery basket, Kickstrip

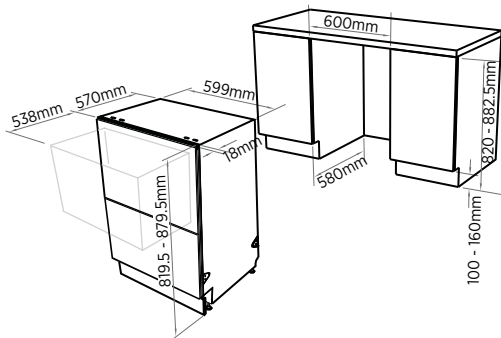

2 YEAR WARRANTY

* Tested to European Standard EN50242

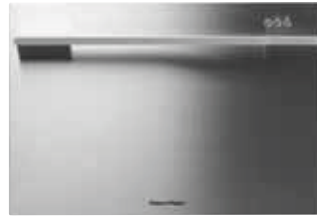

Single DishDrawer®

DD60SDFHX6
EZKleen Stainless Steel
Designer

Dimensions: H409 x W599 x D570 mm

Energy rating*: AAA

Noise level: 44.5 dB

Performance: Smart Drive™ intelligent technology, Intelligent load sensing for optimum performance, Flow through detergent dispenser, Quiet operation

Capacity and loading: 6 Place settings, Flexible racking system, Fold down tines, Adjustable racks and cup racks, Accommodates long stemmed wine glasses, Accommodates plates up to 29cm

Wash programmes: 9 wash programmes, Eco options, Permanent memory of the last cycle used

Safety: Three stage total flood protection

Controls: Easy to use primary and secondary concealed control panel with single touch programming, Key lock, Child lock, End of cycle beeps, One button start, Energy saving delay start option up to 12 hours, Rinse aid indicator light and lens, Electronic fault/Diagnostic indicator

AMP Draw: 5A Minimum

Accessories: Cutlery basket

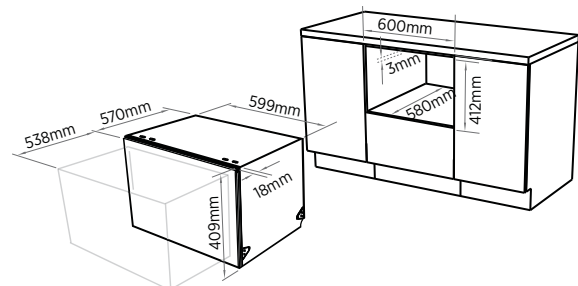

2 YEAR WARRANTY

* Tested to European Standard EN50242



Single DishDrawer®

DD60SHI6 **Kitchen Studio Exclusive**

Integrated (apply your own cabinetry facade)
Designer

Dimensions: H409 x W599 x D570 mm

Energy rating*: AAA

Noise level: 44.5 dB

Performance: Smart Drive™ intelligent technology, Intelligent load sensing for optimum performance, Flow through detergent dispenser, Quiet operation

Capacity and loading: 6 Place settings, Flexible racking system, Fold down tines, Adjustable racks and cup racks, Accommodates long stemmed wine glasses, Accommodates plates up to 29cm

Wash programmes: 9 wash programmes, Eco options, Permanent memory of the last cycle used

Safety: Three stage total flood protection

Controls: Easy to use primary and secondary concealed control panel with single touch programming, Key lock, Child lock, End of cycle beeps, One button start, Energy saving delay start option up to 12 hours, Rinse aid indicator light and lens, Electronic fault/Diagnostic indicator

AMP Draw: 5A Minimum

Accessories: Cutlery basket, Satin Chrome Rectangular Badge

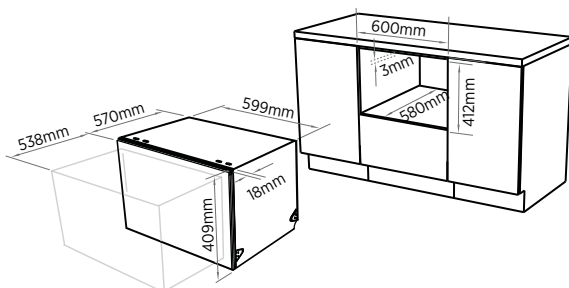

**2 YEAR
WARRANTY**

* Tested to European Standard EN50242



Single DishDrawer®

DD60SCHX6

EZKleen Stainless Steel
Classic

Dimensions: H409 x W599 x D570 mm

Energy rating*: AAA

Noise level: 44.5 dB

Performance: Smart Drive™ intelligent technology, Intelligent load sensing for optimum performance, Flow through detergent dispenser, Quiet operation

Capacity and loading: 6 Place settings, Flexible racking system, Fold down tines, Adjustable racks and cup racks, Accommodates long stemmed wine glasses, Accommodates plates up to 29cm

Wash programmes: 9 wash programmes, Eco options, Permanent memory of the last cycle used

Safety: Three stage total flood protection

Controls: Wash progress and time remaining display, Digital display, Easy to use primary and secondary concealed control panels with single touch programming, Key lock, Child lock, End of cycle beeps, One button start, Energy saving delay start option up to 12 hours, Rinse aid indicator light and lens, Electronic fault/Diagnostic indicator

AMP Draw: 5A Minimum

Accessories: Cutlery basket

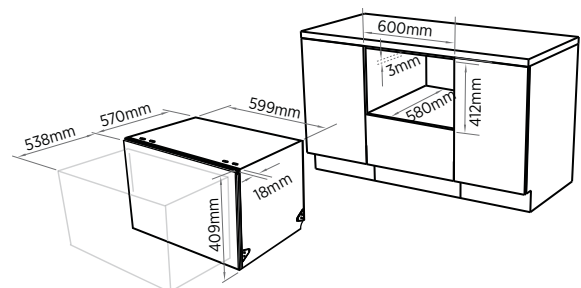

**2 YEAR
WARRANTY**

* Tested to European Standard EN50242



Single DishDrawer®

DD60SCHB6

Black
Classic

Dimensions: H409 x W599 x D570 mm

Energy rating*: AAA

Noise level: 44.5 dB

Performance: Smart Drive™ intelligent technology, Intelligent load sensing for optimum performance, Flow through detergent dispenser, Quiet operation

Capacity and loading: 6 Place settings, Flexible racking system, Fold down tines, Adjustable racks and cup racks, Accommodates long stemmed wine glasses, Accommodates plates up to 29cm

Wash programmes: 9 wash programmes, Eco options, Permanent memory of the last cycle used

Safety: Three stage total flood protection

Controls: Wash progress and time remaining display, Digital display, Easy to use primary and secondary concealed control panels with single touch programming, Key lock, Child lock, End of cycle beeps, One button start, Energy saving delay start option up to 12 hours, Rinse aid indicator light and lens, Electronic fault/Diagnostic indicator

AMP Draw: 5A Minimum

Accessories: Cutlery basket

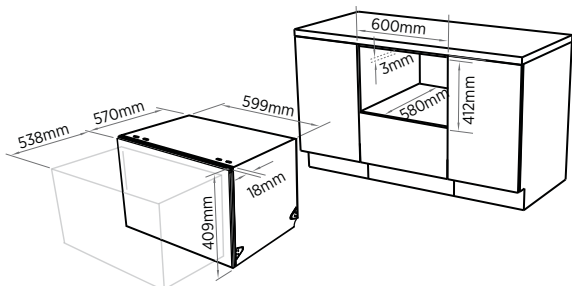

2 YEAR WARRANTY

* Tested to European Standard EN50242



Single DishDrawer®

DD60SCHW6

White
Classic

Dimensions: H409 x W599 x D570 mm

Energy rating*: AAA

Noise level: 44.5 dB

Performance: Smart Drive™ intelligent technology, Intelligent load sensing for optimum performance, Flow through detergent dispenser, Quiet operation

Capacity and loading: 6 Place settings, Flexible racking system, Fold down tines, Adjustable racks and cup racks, Accommodates long stemmed wine glasses, Accommodates plates up to 29cm

Wash programmes: 9 wash programmes, Eco options, Permanent memory of the last cycle used

Safety: Three stage total flood protection

Controls: Wash progress and time remaining display, Digital display, Easy to use primary and secondary concealed control panels with single touch programming, Key lock, Child lock, End of cycle beeps, One button start, Energy saving delay start option up to 12 hours, Rinse aid indicator light and lens, Electronic fault/Diagnostic indicator

AMP Draw: 5A Minimum

Accessories: Cutlery basket

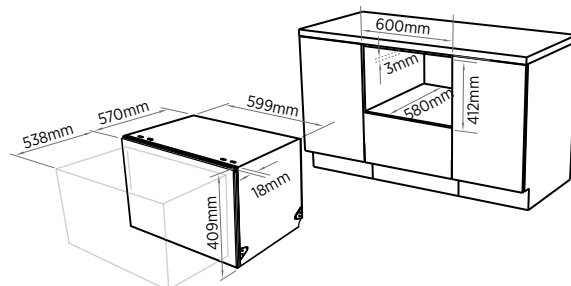

2 YEAR WARRANTY

* Tested to European Standard EN50242

Option 1

DishDrawer® Wide / DishDrawer® Tall /
Single DishDrawer®

Standpipe Ø38mm with Air Gap 750mm to
882.5mm above floor

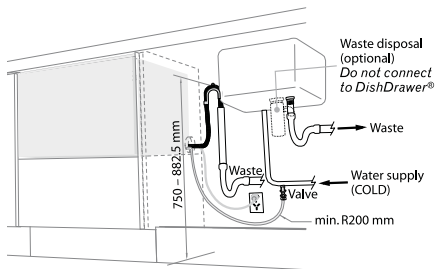

Option 2

DishDrawer® Wide / DishDrawer® Tall /
Single DishDrawer®

DishDrawer® using sink trap with drain hose
joiner Standpipe Ø38mm with Air Gap 750mm
to 882.5mm above floor

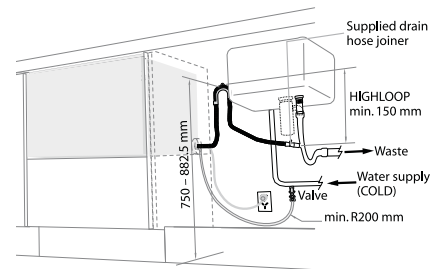

Option 1

Double DishDrawer®

Standpipe Ø38mm with Air Gap 750mm to
882.5mm above floor

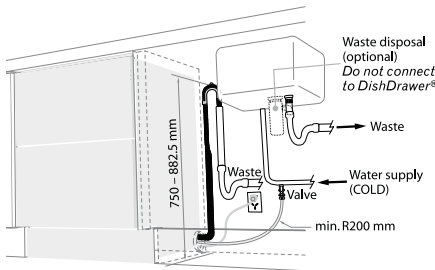

Option 2

Double DishDrawer®

DishDrawer® using sink trap with drain hose
joiner Standpipe Ø38mm with Air Gap 750mm
to 882.5mm above floor

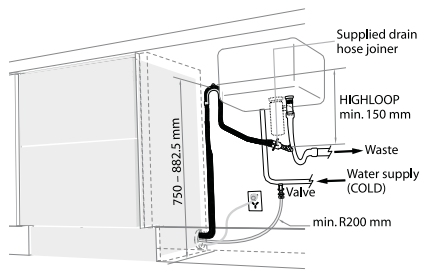



Chrome Rectangular Badge
DD90SHT11, DD60SHT16, DD60SHI6,
DD60DHI6

Match your kitchen decor with the style and colour Integrated DishDrawer® badge that suits.

Part No. 527276



Satin Chrome Rectangular Badge
DD90SHT11, DD60SHT16, DD60SHI6,
DD60DHI6

Satin Chrome badge is supplied as standard with all integrated models. You can purchase one of the other colour or shape options to suit your own kitchen decor.

Part No. 527157



Brass Rectangular Badge
DD90SHT11, DD60SHT16, DD60SHI6,
DD60DHI6

Match your kitchen decor with the style and colour Integrated DishDrawer® badge that suits.

Part No. 527277



Chrome Oval Badge
DD90SHT11, DD60SHT16, DD60SHI6,
DD60DHI6

Match your kitchen decor with the style and colour Integrated DishDrawer® badge that suits.

Part No. 527156



Satin Chrome Oval Badge
DD90SHT11, DD60SHT16, DD60SHI6,
DD60DHI6

Match your kitchen decor with the style and colour Integrated DishDrawer® badge that suits.

Part No. 526684



Black Oval Badge
DD90SHT11, DD60SHT16, DD60SHI6,
DD60DHI6

Match your kitchen decor with the style and colour Integrated DishDrawer® badge that suits.

Part No. 526683



Brass Oval Badge
DD90SHT11, DD60SHT16, DD60SHI6,
DD60DHI6

Match your kitchen decor with the style and colour Integrated DishDrawer® badge that suits.

Part No. 526685



Silver Kickstrip
Supplied with: DD60DDFH6, DD60DCX6

Choose the colour you need to complement your kitchen décor.

Part No. 527108



White Kickstrip
Supplied with: DD60DCHW6

Choose the colour you need to complement your kitchen décor.

Part No. 526680



Black Kickstrip

Supplied with: DD60DCHB6

Choose the colour you need to complement your kitchen décor.

Part No. 526681



Integrated Kickstrip

Supplied with: DD60DI6

Choose the colour you need to complement your kitchen décor.

Part No. 526682



Cutlery Basket

DD90, DD60D, DD60S

Wash more cutlery by adding another basket. The smaller section can be separated and placed into the drawers.

Part No. 522629





Fisher & Paykel

FPBR0410 June 2011

www.fisherpaykel.co.uk

UK

Fisher & Paykel Appliances Limited
Maidstone Road, Kingston, Milton Keynes,
Buckinghamshire, MK10 0BD,
United Kingdom

Customer Care Tel.: 0845 066 2200
Sales and Marketing Tel.: 0845 600 1934
Email.: enquiries@fisherpaykel.co.uk

www.fisherpaykel.ie

Ireland

Fisher & Paykel Appliances
Unit D2, North Dublin Corporate Park,
Swords, Co. Dublin,
Ireland

Office Tel.: +353 (1) 8077960
Office Fax.: +353 (1) 8077961

Customer Care Tel.: 1800 625 174
Sales and Marketing Tel.: 1800 625 173
Email.: enquiries@fisherpaykel.ie

www.fisherpaykel.eu

Europe

Fisher & Paykel Appliances is available
in certain European countries only.
To find a local provider in your country
please visit www.fisherpaykel.eu or email
europe@fp.co.nz

Copyright © Fisher & Paykel 2011. All Rights Reserved. The product dimensions and specifications in this brochure apply to the specific products and models described at the date of issue. Under our policy of continuous product improvement, these dimensions and specifications may change at any time. You should therefore check with your dealer or Fisher & Paykel's Customer Care Centre to ensure this brochure correctly describes the products currently available. You automatically receive a 2 year Manufacturer's Warranty with the purchase of a Product covering parts and labour for servicing within the country of purchase. Our products are only intended for normal domestic use in accordance with the Product's User Guide. Any defects arising from any other use are not covered.

Important Notice of Disclaimer: Our brochure contains information on a wide subject of products which we manufacture and/or sell internationally. Some particular products, models or sizes which are detailed in this brochure may not be available for sale and purchase in your area or country, if available the product may have different options to those depicted in the brochure. Before agreeing to purchase a particular product by reference to this brochure please check its availability and accuracy of its description.

This brochure is printed on paper made from sustainable forests using elementary chlorine-free pulp and vegetable based ink. This brochure represents a green choice by Fisher & Paykel to participate in the growing movement towards social responsibility.